



Model 40. 60, & 80 Series Pumps
Parts Break Down, Model Selection
Trouble Shooting, Inspection and
Assembly Procedures

Table of Contents

Contents	Page Number
Suggested Pump Installation	1
Sidewinder model numbers & pump selection	2
Technical Bulletin-Engineering Change Control Valve Cover with Timer	3
Trouble Shooting Guide	4
Trouble Shooting Questionnaire	5
Parts List	6
Parts Diagram	7
Pump Body & Components Disassembly	8-12
Pump Body & Components Assembly	13-16
Control Timer Disassembly	17-18
Control Timer Assembly	19-21
Ceramic Plunger Installation	22-23
Notes Page	24
Authorized Distributors North America	25



There ain't no better pump!

Suggested Pump Installation and System Set Up

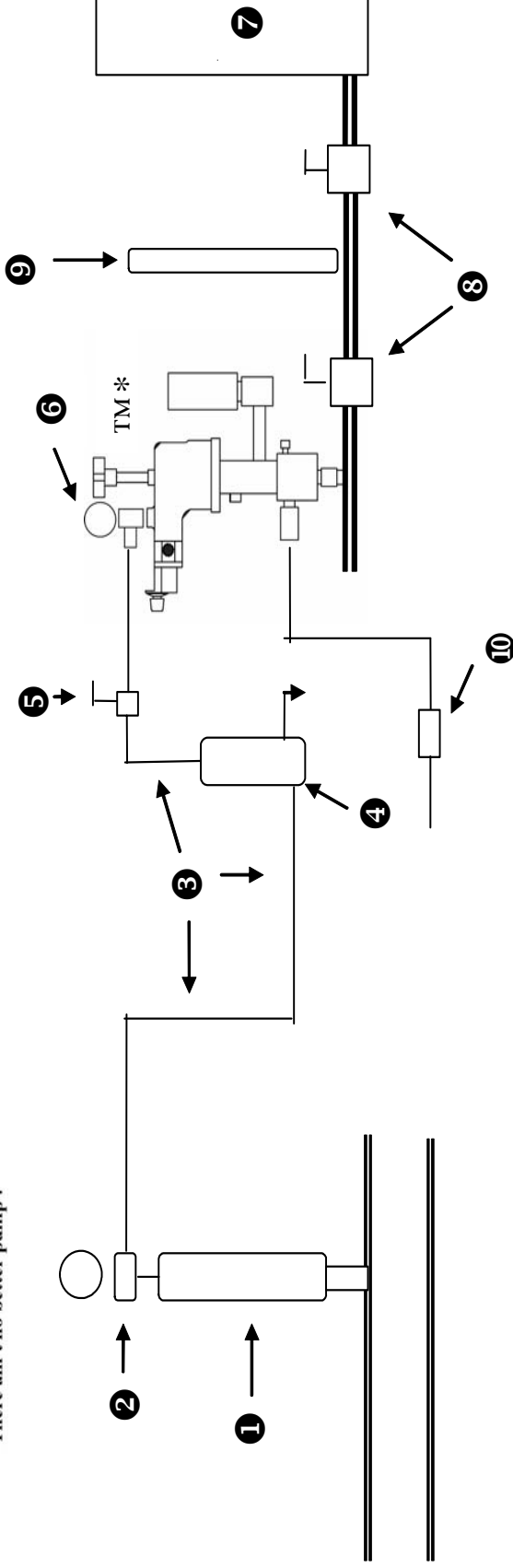

- 1 Scrubber unit installed on supply flow line
- 2 Step down regulator with pressure gauge
- 3 Supply line - 3/8 inch tubing
- 4 Volume bottle / drop out tank with drain
- 5 3/8 inch tubing ball valve - pump supply shut off
- 6 1/4 inch tee at pump supply inlet with pressure gauge
- 7 Chemical supply drum/tank
- 8 Ball Valves -isolation valves for tank/drum, pump setting gauge, & pump
- 9 Pump setting/calibration gauge
- 10 In line discharge check valve

*Sidelwinder Pumps Inc. asserts Trade Mark Rights in and to the distinctive appearance of Sidelwinder Model 40, 42, 60, 62, 80, & 82 series pumps

SIDEWINDER PUMP MODEL NUMBER CHART

Fill in boxes below to determine Sidewinder Pump Size and Material Requirements

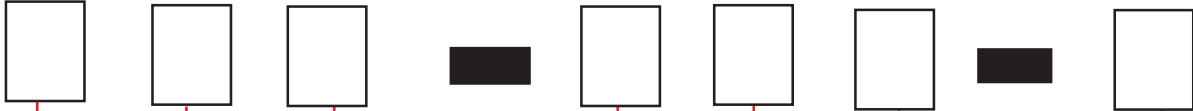

- Plunger Size**
- 04 0.250"
 - 06 0.375"
 - 08 0.500"
 - 16 1.00"

- Piston Size**
- 0 1.25"
 - 2 2.25"
 - 4 4.00"
- Production Series**
- F
 - C
 - C

- Plunger Material**
- 0 17-4 SS (Standard)
 - 2 316 SS
 - 3 440C SS
 - 4 Ceramic
 - 5 Hastelloy
 - 6 Titanium
 - 7 Chrome Plated Stainless Steel
 - 8 Electroless Nickel Plated Stainless Steel

- Check Valve & Body Material**
- 316 SS (Standard) 2
 - Hastelloy 5
 - Titanium 6

- Plunger Packing**
- 0 Teflon Graphite Uniseal
 - 1 Techno Uniseal (Polyimede)
 - 2 Viton O-ring
 - 3 Buna O-ring
 - 4 Teflon Uniseal
 - 4B Teflon Uniseal w/Buna O-ring Insert
 - 4V Teflon Uniseal w/Viton O-ring Insert
 - 5 Chemraz O-ring
 - 6 Hitec O-ring (Aflas)
 - 7 Virgin Teflon O-ring
 - 8 Polyblend Uniseal (UHMW)
 - 9 Special

- Special Options**
- 2-Viton Piston U-Cup
 - 4-Ceramic Check Valve Balls
 - MP- Ni Cobalt Molly Return Spring

PUMP PERFORMANCE CHART

Model Number	Plunger Size	Piston Size	Amplification Ratio	Supply Pressure PSI	Discharge Pressure PSI(a)	Max Full Strokes per minute	Output Volume Qts./Day(b)
40	0.250"	1.25"	25:1	15 to 150	0 to 3,750	60	0 to 90
42	0.250"	2.25"	80:1	10 to 150	0 to 10,000	55	0 to 70
44	0.250"	4"	240:1	10 to 45	0 to 10,000	35	0 to 30
60	0.375"	1.25"	11:1	15 to 150	0 to 1,600	60	0 to 200
62	0.375"	2.25"	36:1	10 to 150	0 to 5,400	55	0 to 155
64	0.375"	4"	110:1	10 to 150	0 to 10,000	30	0 to 67
80	0.500"	1.25"	6.25:1	15 to 150	0 to 935	60	0 to 360
82	0.500"	2.25"	20:1	10 to 150	0 to 3,000	55	0 to 275
84	0.500"	4"	60:1	10 to 150	0 to 9,000	30	0 to 120
164	1.000"	4"	16:1	10 to 150	0 to 2,400	40	0 to 680

SIDEWINDER PUMP ENGINEERING CHANGE

TECHNICAL BULLETIN 10052005

ENGINEERING CHANGE – CONTROL VALVE COVER WITH TIMER

Sidewinder Pumps has made an engineering change in the Control Valve Cover w/Timer, part number 51T-42-2 & Valve Stem part number 33-42.

The Valve Stem part number 33-42 has been modified to a tapered needle, new part number **33-42C**

The Control Valve Cover (*new part number 51T-42C-2*) has been modified, eliminating the **Teflon O-ring Seat (37-42)** and has a tapered orifice to accept the new **Valve Stem (new part 33-42C)**, producing a metal on metal seat.

This design change took place November 15, 2005. with serial number 40755

The design change will also affect the nomenclature describing the pump. The 40/60/80 “**D**” series will become the “**F**” series, the 42/62/82/44/64/84/164 “**B**” series will become the “**C**” series.

The design change will also affect the Timer Valve repair kit – the new part number will be **KVC-40F**. The old kit KVC-40 will still be in production for existing pumps in the field. The *difference* between the kits is the *omission* of the *Teflon O-ring Seat part number 37-42* in the **KVC-40F**.

Existing pumps can be retrofitted with the new Control Valve Cover w/ timer. *The retro fit part number is 30-42C* and consist of the control timer cover (51T-42C-2), timer stem (33-42C), timer knob w/set screw (31-42) and timer stem o-ring (35-42).

Trouble Shooting Guide - Pneumatic Plunger Pumps

Problem	Possible Cause	Action
Control Valve Not Cycling	1) No supply pressure	1) Check gauge on supply line near pump to verify adequate supply pressure - 10 to 150 PSI
	2) Pump speed control closed	2) Rotate dial CCW three turns from full in position and then set desired rate. Rotate CW to slow rate pump rate
	3) Leak in control or valve	3) Check for leak, pinched or missing seals, broken diaphragm or loose mounting screws.
	4) Supply gas blowing through to exhaust due to speed control too wide, trash under valve seat or restriction in air gas/supply line	4) Rotate control dial CW to decrease setting. Block exhaust momentarily and then release. DO NOT USE BARE FINGERS. If this does not work replace Timer Seat O-ring #37 or increase supply line size and move pump closer to air/gas supply source
Piston Not Stroking	1) Return spring broken	1) Replace Spring
	2) Piston stuck due to lack of Piston or Plunger Lube	2) Clean and lubricat power head and piston with Piston Lube #91-42. Clean Plunger Lube Chamber and fill with Plunger lube (#92). Change Piston and plunger seals if needed
	3) Supply pressure too low to buck process line pressure	3) Divide process line pressure by amplification ratio (see Performance Chart). Supply pressure must exceed this result. Standard Sidewinder Control operates from 10 to 150 PSI
	4) Stroke Length Adjuster screwed too far in	4) Back out on stroke adjuster to desired setting.
No Fluid Discharge With Timer Control Cycling and Piston Stroking	1) Air or vapor in pump chamber	1) Open bleeder valve, fill chamber with fluid only, then close bleeder valve.
	2) Fluid flow to pump blocked by plugged line, closed valve, extremely high viscosity or lack of fluid supply	2) Provide free flow of fluid to pump suction.
	3) Suction or discharge check valve leaking	3) Use drum gauge with handle in test position to determine which valve is leaking. Clean or replace faulty valve
	4) Discharge line plugged	4) Clear or replace line.
Premature Seal Failure	1) Chemical incompatibility between seal and material being pumped	1) Check a Compatibility Chart or consult chemical manufacturer, and install seal made from compatible material
	2) Scored or damaged plunger	2) Replace plunger.
	3) Abrasive material in chemical	3) Install suction filter.
	4) No lubricant or incorrect lube	4) Use Sidewinder Lube #91-42 on piston and #92-122 on plunger. Periodically check lube level.

Trouble Shooting Guide Questionnaire



Air Motor Assessment

Is the pump air motor cycling? Yes _____ No _____

If not:

A) is air/gas blowing out exhaust port continuously? Yes _____ No _____

B) is air/gas being exhausted at all? Yes _____ No _____

C) is cycle erratic Yes _____ No _____

D) is air gas escaping from around stroke adjuster? Yes _____ No _____

E) is air gas escaping from around valve body seals? Yes _____ No _____

PUMP END ASSESSMENT

Air motor cycles but pump does not move fluid or build pressure

Is there a pump setting / calibration / drum gauge in the system? Yes _____ No _____

Is there a pressure gauge on the air/gas supply at the pump Yes _____ No _____
If yes, what is the pressure reading? _____

Is there a pressure gauge on the discharge line of the pump? Yes _____ No _____
If yes what is the pressure reading? _____

Does the pump lose flow when the system starts to pressurize? Yes _____ No _____

Is the plunger moving up & down Yes _____ No _____
Observe plunger thru the breather port under the power head.

Is chemical appearing in the lube bottle? Yes _____ No _____

Isolating the pump setting / calibration gauge / drum gauge) with the pump running:
Does the fluid in the gauge fluctuate up & down? Yes _____ No _____

Does the fluid in the gauge move? Yes _____ No _____

Model 40/60/80 Parts List

\ No.	Qty Req	Part Description	Part # Model 40	Part # Model 60	Part # Model 80
1	1	Stroke Adjuster	1-40-C	1-40-C	1-40-C
2	1	Locknut-Stroke Adjuster	2-40	2-40	2-40
3*	1	Seal-Stroke Adjuster	3-40	3-40	3-40
4	1	Powerhead	4-40-2	4-40-2	4-40-2
4A	3	Lockscrews	4A-42-B	4A-42-B	4A-42-B
6*	1	U-Cup - Standard Material Buna N Construction	6-40	6-40	6-40
6*	1	U-Cup - Option Material Viton Construction	6-40-2	6-40-2	6-40-2
11*	1	Return Spring Standard	11-42	11-42	11-42
11*	1	Return Spring Option Ni Cobalt Moly Construction	11-42-MP	11-42-MP	11-42-MP
12	1	Mounting Tube	12C-40	12C-60	12C-80
13A	1	Vent	13A-42	13A-42	13A-42
14	1	Lubricator	14-430	14-430	14-430
15	1	Lube Tube	15-40	15-40	15-40
16*	1	Piston-Plunger-17-4 SS	16-40	16-60	16-80
		Piston-Plunger 316 SS	16-40-2	16-60-2	16-80-2
		Piston-Plunger-440 SS	16-40-3	16-60-3	16-80-3
		Piston-Plunger-Ceramic	16-40-4	16-60-4	16-80-4
		Piston-Plunger-Hastelloy	16-40-5	16-60-5	16-80-5
		Piston-Plunger-Titanium	16-40-6	16-60-6	16-80-6
		Piston-Plunger-SS w/ chrome plating	16-40-7	16-60-7	16-80-7
		Piston-Plunger-SS w/ electroless nickel plating	16-40-8	16-60-8	16-80-8
		Customer Specified Special	16-40-9	16-60-9	16-80-9
17*	1	O-Ring Mounting Tube	17-42	17-42	17-42
18*	1	Plunger Seal-Teflon Carbon Filled Graphite Uniseal	18-42	18-62	18-82
		Plunger Seal-Techno Uniseal (Polyimide)	18-42-1	18-62-1	18-82-1
		Plunger Seal-Viton O-Ring	18-42-2	18-62-2	18-82-2
		Plunger Seal-Buna O-Ring	18-42-3	18-62-3	18-82-3
		Plunger Seal-Virgin Teflon Uniseal	18-42-4	18-62-4	18-82-4
		Plunger Seal-Virgin Teflon Uniseal w/Buna Insert	18-42-4B	N/A	18-82-4B
		Plunger Seal-Virgin Teflon Uniseal w/Viton Insert	18-42-4V	18-62-4V	18-82-4V
		Plunger Seal Chemraz O-Ring (Kalrez equivalent)	18-42-5	18-62-5	18-82-5
		Plunger Seal-Hitec O-Ring (Aflas)	18-42-6	18-62-6	18-82-6
		Plunger Seal Virgin Teflon O-Ring	18-42-7	18-62-7	18-82-7
		Plunger Seal-Polyblend Uniseal	18-42-8	18-62-8	18-82-8
		Customer Specified Material	18-42-9	18-62-9	18-82-9
<i>NOTE: O-ring seals for Model 40 pumps require (1) O-ring and two (2) narrow back up rings. (18D-42). Model 60 pump require (2) O-rings and three (3) narrow back up rings. (18D-62). Model 80 pump require (1) O-ring and two back up rings (18D-82). Uniseals do not require back up ring</i>					
20	1	Bleeder Valve	20-42-2	20-42-2	20-42-2
22*	1	Suction Check Valve	22-42-2	22-82-2	22-82-2
23*	1	Discharge Check Valve	23-42-2	23-42-2	23-42-2
24	1	Pump Chamber	24-42-2	24-62-2	24-82-2
31	1	Control Knob	31-42	31-42	31-42
33	1	Timer Stem (For Pumps Prior to s/n # 40755 - Nov '05)	33-42	33-42	33-42
33	1	Timer Stem (For Pumps After s/n # 40755 - Nov '05)	33-42C	33-42C	33-42C
35**	1	O-Ring Stem	35-42	35-42	35-42
37**	1	Timer Seat O-Ring (Teflon) (Deleted on pumps after ser # 40755, Nov '05)	37-42	37-42	37-42
51	1	Control Valve Cover with Timer (Prior to s/n 40755) Replace w/ 51T-42C-2	N/A	N/A	N/A
51	1	Control Valve Cover with Timer (Pumps after #40755 Nov '05)	51T-42C-2	51T-42C-2	51T-42C-2
52**	1	Diaphragm	52-42	52-42	52-42
53	1	Control Valve Body	53-42-2	53-42-2	53-42-2
54**	1	Actuator	54-42	54-42	54-42
55**	1	Poppet	55-42	55-42	55-42
56**	1	Body Seal	56-42	56-42	56-42
57**	1	Spring	57-42	57-42	57-42
58**	2	Mounting Screw	58-42	58-42	58-42
75**	2	Mounting Screw Washer	75-42	75-42	75-42
92*	1	Plunger Lube (2 o.z.)	92-42	92-42	92-42

Notes

*Parts included in a pump end repair kit. Also included is a 91-42 Silicone Piston Grease. This kit is designated by a "K" preceding the pump model number. The D & F series in the Model 40/60/80 use the same Pump End Repair Kit.

** Parts included in a timer valve repair kit. This part number is KVC-40 for the Model 40, Model 60 and Model 80 pumps prior to s/n 40755 - for pumps after s/n 40755 - Nov '05 kit part number is KVC-40F

NOTE: First generation Model 40 & Model 80 Sidewinder Pumps are denoted by serial numbers before 5821. These models require a 9-42 Spiral Ring and only one 4A-42 Lockscrew.

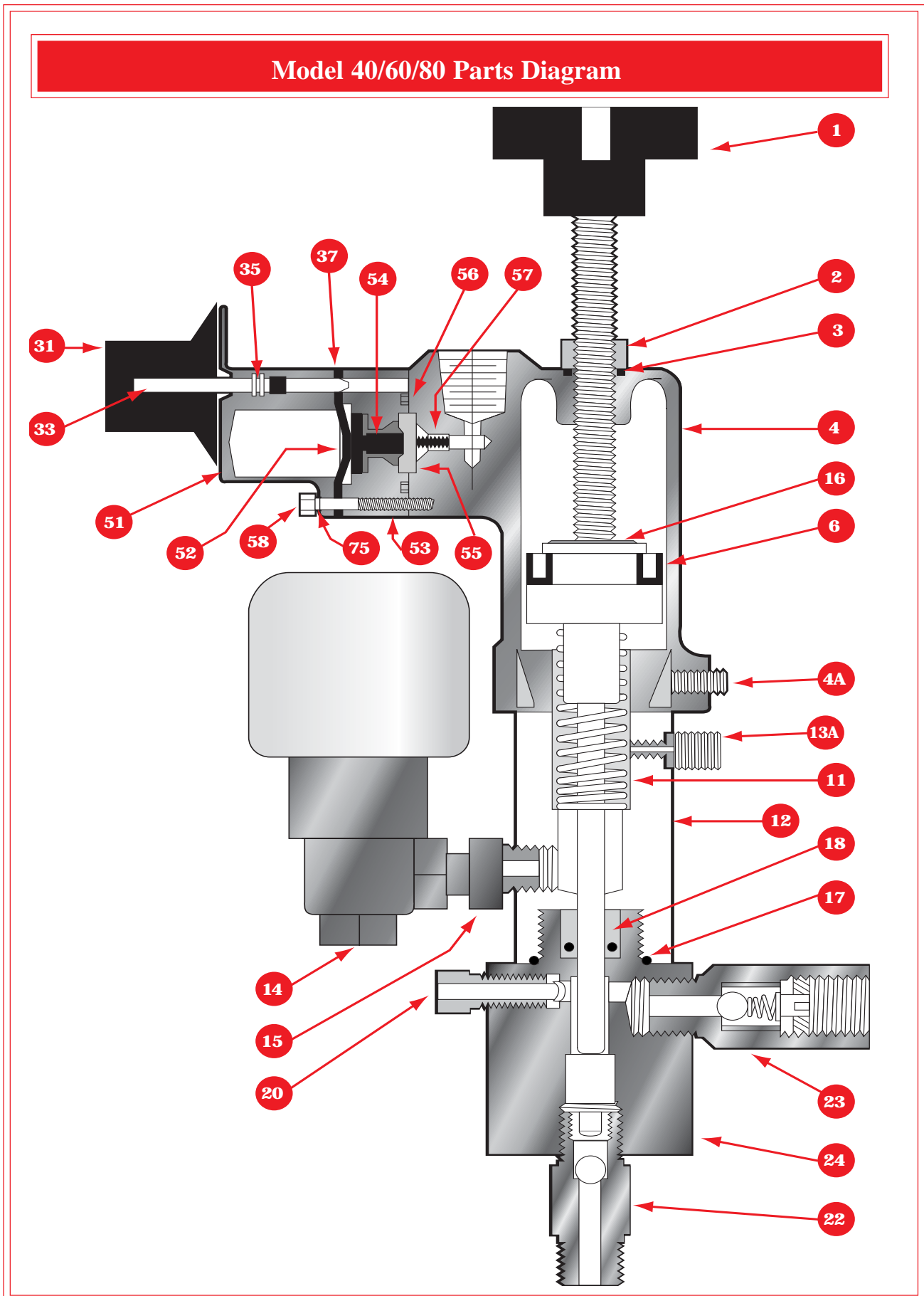

Sidewinder Pumps Inc. asserts Trade Mark Rights in and to the distinctive appearance of Sidewinder Model 40, 42, 60, 62, 80, and 82 pumps

Model 40, 60, 80 Series Pump Body and Components Disassembly and Inspection

1. Locate the three lock screws (item 4a) on power head and remove. Figure 1a



2. Remove Power Head (item 4) with plunger assembly (item 16). Remove plunger assembly from power head. Inspect lower end of plunger for wear. Remove plunger U-cup (item 6) and inspect for cuts and tears.



2a



2b

3. Remove return spring (item 11) and check for breaks. Remove vent (item 13a) from mounting tube (item 12). Inspect vent – when shaken, vent should make rattling

sound. Holding the pump chamber (item 24) securely, unscrew the mounting tube (item 12). Figures 3a to 3 d.



3a



3b



3c



3d

4. Remove mounting tube o-ring (item 17), inspect for tears and cuts. For pumps equipped with the Uniseal arrangement, fill the pump chamber (item 24) with water. Insert plunger assembly (item 16) partially into seal. Holding pump chamber and sealing off the discharge check (item 23), firmly & quickly push plunger assembly down. This should force the Uniseal out of the seal chamber of the pump chamber seal gland. **NOTE:** This procedure may need to be repeated several times. If seal is damaged and will not hold pressure, seal will have to be removed with o-ring pick. Take care not to scratch or damage walls of seal area on pump chamber. Figures 4a to 4f.



4a



4b



4c



4d



4e



4f

5. For Model 40 & 80 series pumps equipped with the o-ring seal arrangement, there are three components. The o-ring is sandwiched between two back up rings. On Model 60 series there are five components. Two O-rings sandwiched between three back up rings. The back up rings and the o-ring are removed with an o-ring pick. Care should be taken not to scratch or damage the seal surface of the pump chamber. Figures 5a to 5c.



5a



5b



5c

6. Remove suction check valve (item 22) from pump chamber. When shaken check valve should rattle. To inspect check valve, use 3/16 allen wrench to remove retainer. After removing retainer the check ball should fall out. Inspect ball and seat for wear and deposits. Installation is reversal of this procedure. Retainer is screwed in until flush with body of valve. Figures 6a to 6d.



6a



6b



6c



6d

7. Remove discharge check valve (item 23) from pump chamber. Using 3/16 allen wrench to remove retainer from valve. Remove ball and spring from valve. Tap valve with retainer end down on table to remove seat. Inspect spring, ball and seat. Clean and reassemble in reverse order. Figures 7a to 7d.



7a



7b



7c



7d

8. Remove bleeder valve (item 20) from pump chamber. Inspect for blockage, clear with compressed air. Figures 8a to 8b.



8a



8b

Model 40, 60, 80 Pump Body and Components Assembly

1. Install seal (item 18) into pump chamber seal gland. Uniseals are a single unit and are installed with lip / spring facing down. O-ring arrangements are composed of three items – two ea back up rings (part number 18D-xx) and an o-ring. Insert one back up ring, then the o-ring, then the last back up ring. Figures 1a to 1c.



1a



1b



1c

2. Take the pump chamber (item 24) and install the mounting tube o-ring (item 17), bleeder valve (item 20), suction check valve (item 22), and discharge check valve (item 23) **NOTE:** The check valves are marked for direction of flow. **NOTE:** Threaded items should have two wraps of Teflon tape starting one to two threads back from thread end. Figures 2a to 2d. **NOTE:** Do not use excessive Teflon tape, as the tape can become displaced and enter into the fluid passage ways blocking flow.



2a



2b

2. Continued



2c



2d

3. Thread mounting tube (item 12) onto the pump chamber (item 24). Note this should be hand tight. Install lube tube (item 15), & vent (item 13A). Figure 3a & 3b



3a



3b

5. Place stroke adjuster seal (o-ring item 3) onto stroke adjuster and thread stroke adjuster into power head (item 4). Thread the stroke adjuster into power head until threads are flush with housing on inside. Tighten lock nut (item 2). Figure 5a to 5c.



5a



5b



5c

6. Insert piston seal (u-cup item 6) on to plunger assembly.
NOTE: Open lip of seal should be facing top of piston.
 Figure 6a.



6a

7. Back off power head (item 4) lock screws (item 4A) enough to mount head on to mounting flange (item 10).
 8. Place small amount of silicone piston grease (part number 91-42) in seal chamber of power head (item 4) and coat surface. Place small amount of silicone piston grease around exterior surface of the piston seal (item 6). Put small amount of plunger seal lubricant (item 92) on working surface of plunger. Insert plunger assembly into power head. Figures 8a to 8d.



8a



8b



8c



8d

9. Insert return spring (item 11) into mounting tube (item 12)



10. Mount power head (item 4) with plunger assembly to mounting flange (item 10), inserting plunger into seal as putting power head down onto mounting flange. Tighten lock screws (item 4A) enough so power head can still be rotated. Rotate power head until desired position then tighten lock screws (item 4A). Install lube bottle. Figures 10a to 10c.



10a



10b



10c

Control Timer Disassembly

1. Remove the two allen head screws (item 75) holding the Control Timer Assembly to the power head with an $7/64$ allen wrench. Separate the control valve body (item 53) from the control valve cover with timer (item 51). Pay special attention to the orientation of the control valve diaphragm (item 52) and the orientation of the control valve body (item 53) to the power head. Figures 1a to 1c.



1a



1b

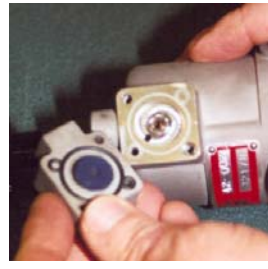

1c

2. Remove the diaphragm (item 52) from the control valve body. Remove the control valve poppet (item 55). Remove the control valve body seal (item 56). Remove the control valve actuator (item 54). Remove the poppet return spring (item 57). Special attention should be given to the orientation of these items as they are removed. Figures 2a to 2e.



2a



2b



2c

2. Continued



2d



2e

3. Remove timer control valve stem (item 33) from timer cover. Remove o-ring (item 35) from valve stem. On pumps before serial number #40755 remove the Teflon O-ring seat (item 37) from control valve cover with timer (item 51). 3a to 3c. Pumps after serial number #40755 do not have this Teflon O-ring.



3a



3b



3c

Control Timer Assembly

1. For pumps before serial # 40755-install stem o-ring (item 35) onto valve stem (item 33). Screw valve stem into control valve cover (item 51) until chamfer extends past the flat of control valve body. Pumps after serial # 40755 skip this step.



2. Insert Teflon O-ring seat (item 37) over valve stem (item 33), using insert tool press O-ring into place. If necessary trim flashing from edge of O-ring. Unscrew valve stem until back edge of chamfer engages o-ring seat.



2a



2b

3. Holding control valve cover with control knob downward, insert diaphragm (item 52), take note diaphragm dog ear fits over the Teflon o-ring seat and the opposite corner. Put the actuator (item 54) on top of the diaphragm, large end to the diaphragm.



3a



3b

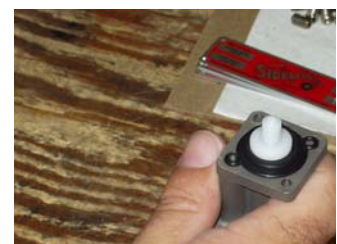

3c

4. Put the control valve body (item 53), flat side down on top of diaphragm and actuator. There is a line up indentation that fits over the line up shoulder of one of the screws.



4a



4b

5. Insert valve body seal (item 56) into groove on valve body. Insert poppet (item 55), with the three dimples facing outward, into valve body.



5a



5b

6. Install spring (item 57) into power head, install timer assembly to the power head with time knob to the top. Tighten screws alternately until assembly is snug.



6a



6b

Ceramic Plunger

Sidewinder Pump Models 40, 60, 80, 42, 62, 82 Handling, Installation, Start-up, & Operating Instructions

1. This is a solid ceramic plunger. It is very brittle and **must** be handled with extreme care before & during use in a Sidewinder Pump.

2. When installing:
 - a) Be sure the Pump Chamber (Item #24) is separated from the Mounting Tube (Item #12).
 - b) Be sure the Powerhead (Item #4) is removed from Mounting Flange(for Models 42,62,82) or Mounting Tube(for Models 40,60,80).
 - c) **Model 42,62,82 only:** Mounting Flange (Item #10) should still be connected to the Mounting Tube (Item #12) by the Mounting Tube Locknut (Item #7A).
 - d) Place Piston U-cup (Item #6) on piston with “U” facing away from plunger side.
 - e) Upon assembly be sure the Powerhead (Item #4) is lubricated with Piston Grease (P/N 91-42). Grab the Ceramic Piston Plunger Assembly (Item #16) by the metal shank above the ceramic plunger and insert the piston into the Powerhead (Item #4) by cocking the assembly then straightening it. Be sure the Piston U-cup (Item #6) is not crimped or folded over.

Note: Never grab the Piston Plunger Assembly by the ceramic plunger.

- f) Once the Ceramic Piston Plunger Assembly (Item #16) is inserted into the Powerhead (Item #4), push it to the top of the cylinder bore. Install the Return Spring (Item #11) around the metal shank portion of the Piston Plunger Assembly (Item #16) being sure it is slides into position against the piston portion of the assembly.
 - g) Mount the Powerhead & the Piston Plunger Assembly with Return Spring in place onto & into Mounting Flange & Mounting Tube, respectively. **Caution should be used as the ceramic plunger passes through the seal retainer hole in the lower portion of the Mounting Tube (Item #12). Too much side-to-side motion can bind the plunger causing it to break.**
 - h) Once Powerhead (Item #4) is fully in place on the Mounting Flange(for Models 42,62,82) or Mounting Tube(for Models 40,60,80) secure it by screwing in the three radial Lockscrews (Item #4A) evenly until tight.
 - i) Screw the Pump Chamber (Item #24) onto the Mounting Tube (Item #12) insuring that the Plunger Seal (Item #18) & Mounting Tube O-ring (Item #17) are installed into and onto the Pump Chamber, respectively. The Pump Chamber and Mounting Tube connection is designed to be hand tight. **Caution: Tightening the Pump Chamber (Item #24) and the Mounting Tube (Item #12) with wrenches can cause the two pieces to gall.**
- 3) When starting pump into operation:
 - a) Open the Bleeder Valve (Item #20) to prime pump.

Ceramic Plunger

Sidewinder Pump Models 40, 60, 80, 42, 62, 82 Handling, Installation, Start-up, & Operating Instructions

- a) Make sure the Control Knob (Item #31) is screwed in all the way to insure that the pump is off.
- b) Back off on the air/gas supply regulator to 0 PSI.
- c) Slowly bring the supply pressure up to 10 PSI (regardless of fluid injection pressure).
- d) Slowly begin to unscrew the Control Knob (Item #31) until the pump begins to stroke at a rate of 1 stroke every 3-4 seconds.
- e) Allow the pump to run in this condition until the injection lines fill and pump stalls against the injection pressure. (When pump stalls, the Control Valve will continue to shift and in fact speed up slightly, but the Piston Plunger Assembly (Item #16) will no longer be moving up and down. This can be confirmed by removing the Vent (Item #13A) on the Mounting Tube (Item #12) and observing. If the Control Valve blows a continuous stream of air instead of cycling, increase the air/gas supply pressure slightly. After raising the air/gas supply pressure slightly the Control Valve continues to blow a continuous stream of air/gas it will be necessary to place a solid object over the exhaust port, interrupting the flow of air/gas for one second to reset the Control Valve.
- f) Once the pump stalls, slowly increase the air/gas supply regulator pressure until movement of the Piston Plunger Assembly begins. **Do not use more air/gas supply pressure than needed to cycle the pump.** Too much air/gas supply pressure will cause the Piston Plunger Assembly to slam down which can break the ceramic plunger portion of the assembly.
- g) Increase or decrease pump volume by using either or both the Control Knob (Item #31) and the Stroke Adjuster (Item #1).

NOTES



Sidewinder Pumps Authorized Distributors North America

ARKANSAS

SPECTRUM SERVICES

FT. SMITH
5709 Rogers Avenue
TEL: 479-484-9474
FAX:

CALIFORNIA

FRED C. GILBERT CO.

BAKERSFIELD
106 Norris Road
TEL: 661-399-9569
FAX: 661-393-9654

COLORADO

POWER CONTROLS INC.

DENVER
1205 W. Center Avenue
TEL: 303-777-3100
FAX: 303-777-4412

LOUISIANA

AGI Industries

LAFAYETTE, LA
Hwy 90 East
TEL: 337-233-0626
FAX: 337-233-0828

MARRERO, LA
4612 4th Street
TEL: 504-340-6905
FAX: 504-348-2593

SULPHUR, LA
106 Bayou Bend
TEL: 337-626-7867
FAX: 337-626-0668

RMC Sales Inc.
BOSSIER CITY; LA
565 Sligo Road
800-523-4055
318-747-0645

NEW MEXICO

JET SPECIALTY

EUNICE
1207 Texas Avenue
TEL: 505-394-0746
FAX: 505-394-0748

HOBBS
1011 S. Leech Street
TEL: 505-397-5038
FAX: 505-393-7691

OHIO

RDM EQUIPMENT Co.

WOOSTER
1141 Mechanicsburg
TEL: 330-264-8808
FAX: 330-262-0499

OKLAHOMA

JET SPECIALTY

ELK CITY
817 N. Van Buren
TEL: 580-225-4538
FAX: 580-218-9861

OKLAHOMA CITY
713 N. Morgan Rd
TEL: 405-789-5260
FAX: 405-499-9840

TULSA
4339 S. 93rd East Ave
Suite #A
TEL: 918-641-1170
FAX: 918-641-3538

TEXAS

A&G Supplies

DICKINSON
1314 FM 646
Suite 14
Tel. 281-309-9979
Fax 281-309-9989

FLOWZONE

PEARLAND
2530 Garden Road
BLDG. F
TEL: 281-997-8899
FAX: 281-997-8891

JET SPECIALTY

CORPUS CHRISTI
6901 Leopard
TEL: 361-888-8496
FAX: 361-888-4531

ELDORADO, TX
1100 Orient St.
TEL: 325-853-2992
FAX: 325-853-2995

HASLET
1150 Blue Mound Rd
Suite #302
TEL: 817-439-3681
FAX: 817-439-1352

HELOTES
13313 Western Oak
TEL: 877-408-0905
AX: 210-408-0140

TEXAS continued

LONGVIEW, TX
102 F Rothrock Dr.
TEL: 903 757-9610
FAX: 903-757-9588

ODESSA
809 W. 2ND Street
TEL: 432-332-0456
FAX: 432-498-7346

OZONA, TX
800 Ave G.
TEL: 325-392-9900

SONORA
198 Private Road
#4489
TEL: 325-387-61133/3/2005
FAX: 325-387-6121

SUWANNEE PIPE & SUPPLY

VICTORIA
3804 Billy Drive
TEL: 361-572-8371
FAX: 361-578-0834

CANADA

BRUIN INSTUMENT
EDMONTON, ALBERTA
EDMONTON
9001 - 20 Street
TEL: 780-430-1777
FAX: 780-430-1412

WELLMASTER PIPE & SUPPLY
TILLONSBURG, ONTARIO
1494 Bell Mill Side Rd.
TEL: 519-688-0500
FAX: 519-688-0563

MEXICO

Industrial Aldake S.A de C.V
POZA RICA, VER. MEXICO
TEL: 782-822-1132 / 0835 / 6809
FAX: 782-823-1779

TRINIDAD Neal & Massy Energy Services

LTD
Tel. 868-657-8622
Fax. 868-657-2652

Sidewinder Pumps Inc. Information

Sidewinder Pumps Inc.

Office Phone : (337)-235-9838

Office Fax : (337)-235-9852

Mailing Address:

P.O. Box 80769

Lafayette, Louisiana USA 70598-0769

Physical / Shipping Address

2108 S. E. Evangeline Thruway

Lafayette, Louisiana, USA 70508

V.P. / General Manager: Paul George

Marketing Director: Guy M. Chachere

Office Manager: Cathy Louviere

Production Manager: Bob Ritcher

Website: www.sidewinderpumps.com

Email:

Information: info@sidewinderpumps.com

Orders: sales@sidewinderpumps.com

Quotes: quotes@sidewinderpumps.com

January, 2007