

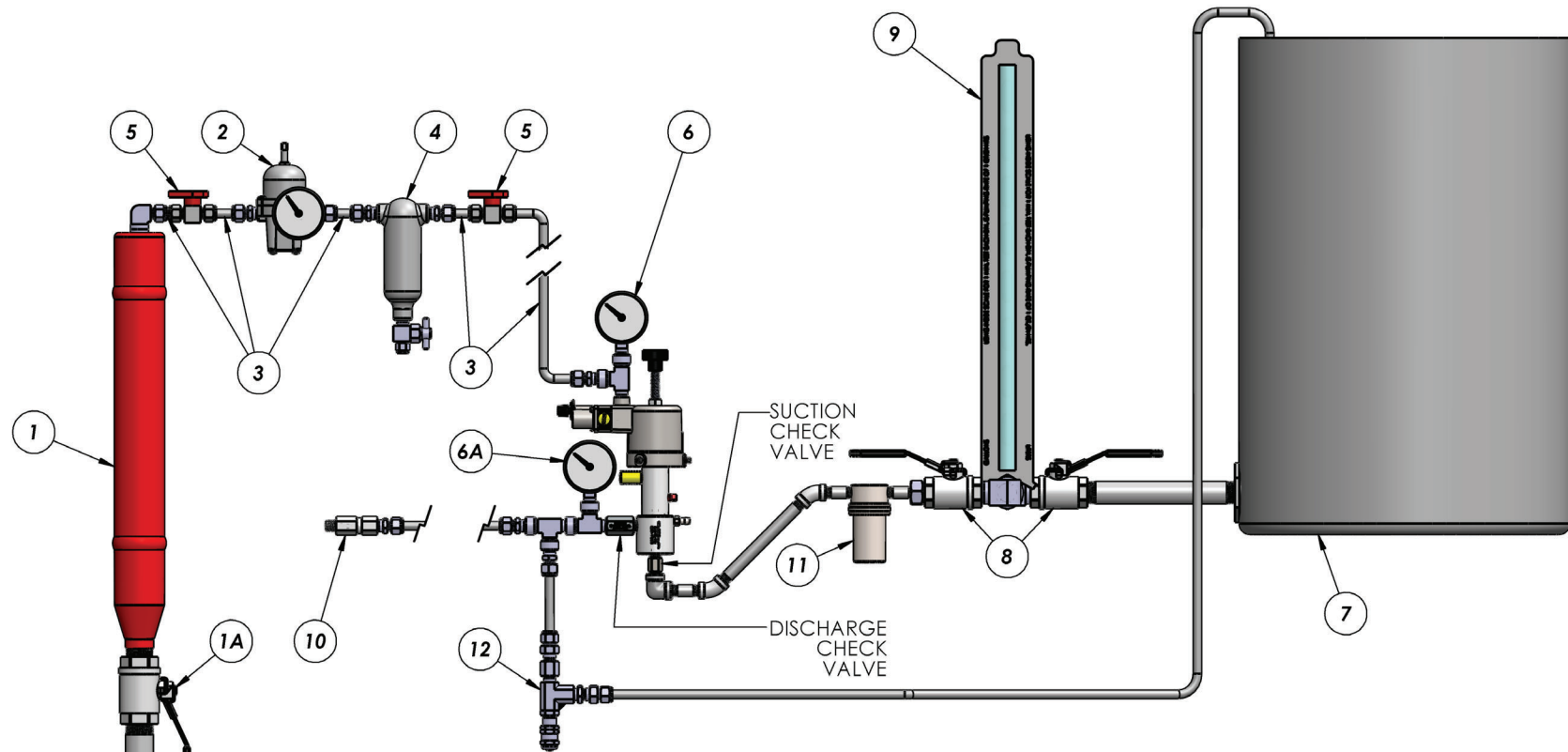

Suggested Pump Installation and System Set Up

There ain't no better pump



LEGEND

- | | |
|--|---|
| 1) SCRUBBER UNIT INSTALLED ON SUPPLY FLOW LINE | 6A) 1/4" TEE AT PUMP DISCHARGE WITH PRESSURE GAUGE |
| 1A) BALL VALVE - FLOW LINE | 7) CHEMICAL SUPPLY DRUM / TANK |
| 2) STEP DOWN REGULATOR WITH PRESSURE GAUGE | 8) BALL VALVES - ISOLATION VALVES FOR TANK |
| 3) SUPPLY LINE 3/8" TUBING | 9) PUMP SETTING GAUGE |
| 4) VOLUME BOTTLE / DROP OUT TANK WITH DRAIN | 10) IN-LINE DISCHARGE CHECK VALVE (AT POINT OF ENTRY) |
| 5) BALL VALVE | 11) IN-LINE SUCTION FILTER |
| 6) 1/4" TEE AT PUMP SUPPLY INLET WITH PRESSURE GAUGE | 12) RELIEF VALVE (SET AT 10% OVER M.O.P.) |