



P. O. Box 80769 • Lafayette, LA 70598-0769 • (337) 235-9838 • FAX (337) 235-9852 • www.sidewinderpumps.com

Solar Powered - Chemical Injection Pump

Suggested Installation & Operating Instructions

BASIC SYSTEM SETUP:

Step 1: INSTALL SOLAR PANEL(S) - If your solar panel is supplied by Sidewinder, install it with the supplied mounting components. A simple tee type mount is supplied and pre-attached on single panel setups, and is part of the install kit for double panel setups. Separate instructions will be included with the solar panel kit. Set the tee on top of the stand pole, point the panel to the south and tighten the lower set screw. Adjust the tilt of the panel to the suggested degree of inclination. ***Use care to avoid damage to the glass panels. Location MUST provide full southern exposure with NO SHADE.***

Step 2: MOUNT THE PUMP - Securely fasten your Sidewinder Pump in the desired location. Sidewinder offers a welded skid providing the mounting location for the pump and also stand-alone stands for the pump. As an alternate, the integral pump motor mount can be bolted directly to any existing structure.

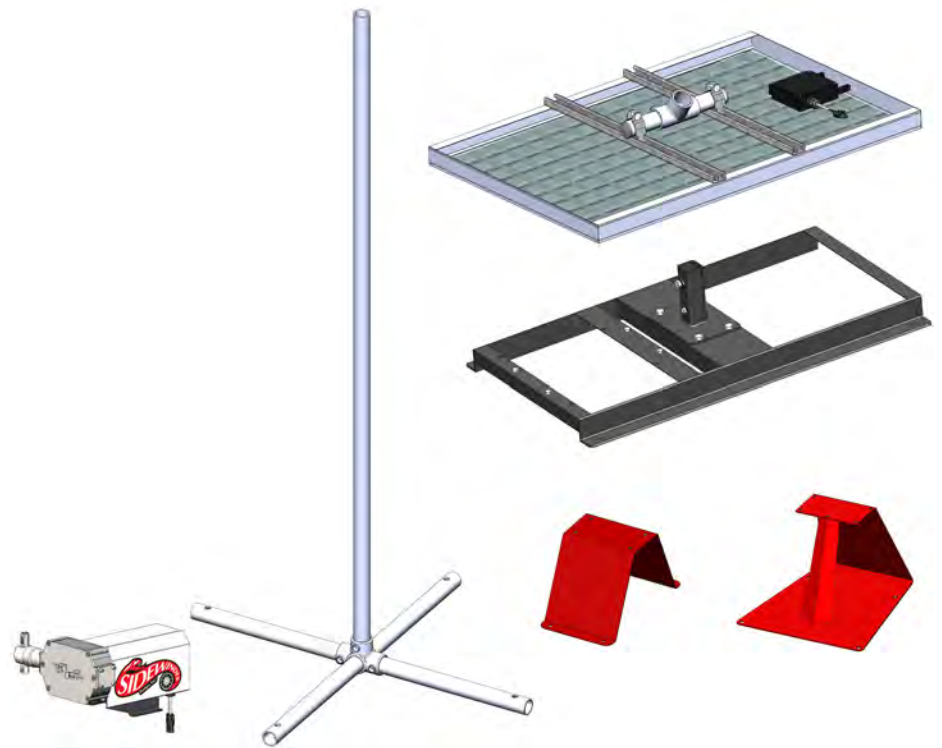

Step 3: PLUMBING THE PUMP: (See Illustration below – duplex version shown)

- a) Install pump setting gauge between two isolation ball valves as shown below.
- b) Install pump with suction filter and isolation ball valve between the pump and the pump setting gauge.
- c) Connect the feed line to the Suction Check Valve(s) using 1/4" MNPT connectors.
- d) Connect the discharge line to the Discharge Check Valve(s) using 1/4" MNPT connectors.
- e) 1/8" FNPT ports are provided for detection of seal leakage. They may be used to plumb drainage to containment area.

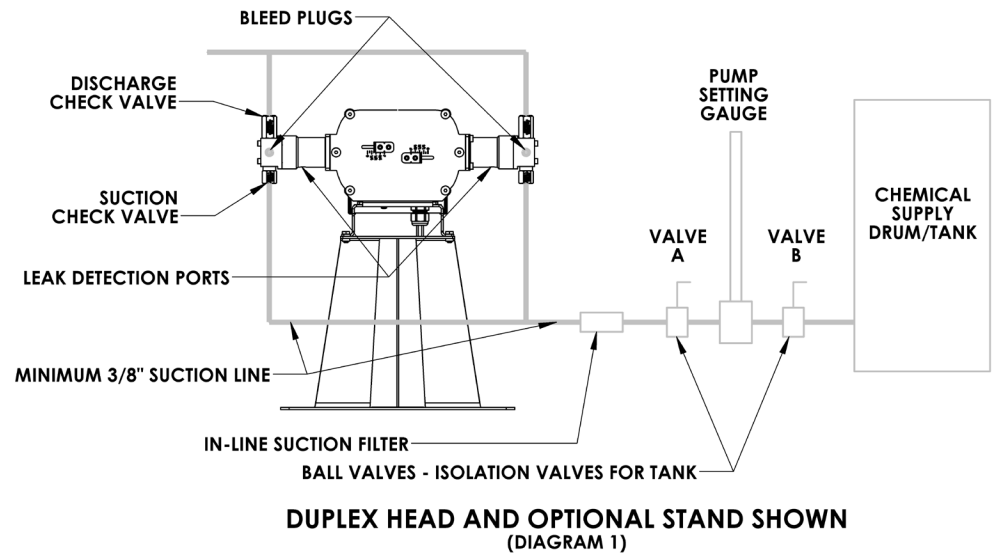

- f) **NOTE: Industry safety practice requires installation of a properly sized pressure safety valve at the discharge side of the pump.**
- g) **NOTE: Sidewinder Pumps Inc. strongly recommends the addition of a line check valve at the point of injection.**

h) **NOTE: Do not use non-metallic discharge lines.**

i) **NOTE: If using a “Divider Block” in the discharge line, a pressure safety valve must be installed in the discharge line at the pump. Failure to do so will void the pump warranty and most importantly, will create a safety hazard! (See Note “ f ” above also)**

Step 4: Wiring the Panel & Pump – Your Sidewinder pump requires a timing device to cycle the pump on and off to effectively control pump output. Sidewinder offers control boxes that contain a timer, charge controller, and storage area for your system battery. Connections to the pump motor and solar panel(s) are accomplished via dedicated wiring harnesses and can only be connected one way. Use weatherproof snap fit harnesses available from Sidewinder.

PARTS LIST: MAIN PUMP ASSEMBLY

Pump part number structure:

	1-SIMPLEX; 2-DUPLEX
	PRESSURE RATING
	PLUNGER SIZE
	PLUNGER SEAL
	CHECK VALVE THREAD O-RING
	CHECK VALVE BALL
	WET END
	PLUNGER OPTIONS
S	<input type="checkbox"/> <input type="checkbox"/> <input type="checkbox"/> <input type="checkbox"/> <input type="checkbox"/> <input type="checkbox"/> <input type="checkbox"/> <input type="checkbox"/>

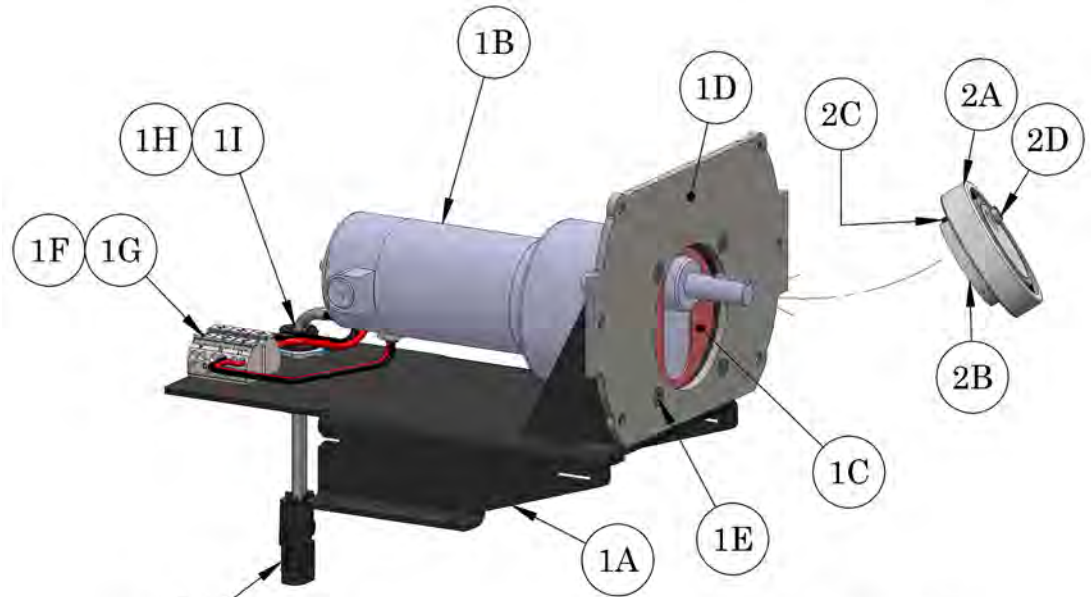

1J * IF ITEM "1J" IS NOT PROVIDED FOR YOUR APPLICATION, THE MOTOR WIRES MAY BE CONNECTED DIRECTLY TO ITEM "1F", THROUGH ITEM "1H", CORD GRIP.

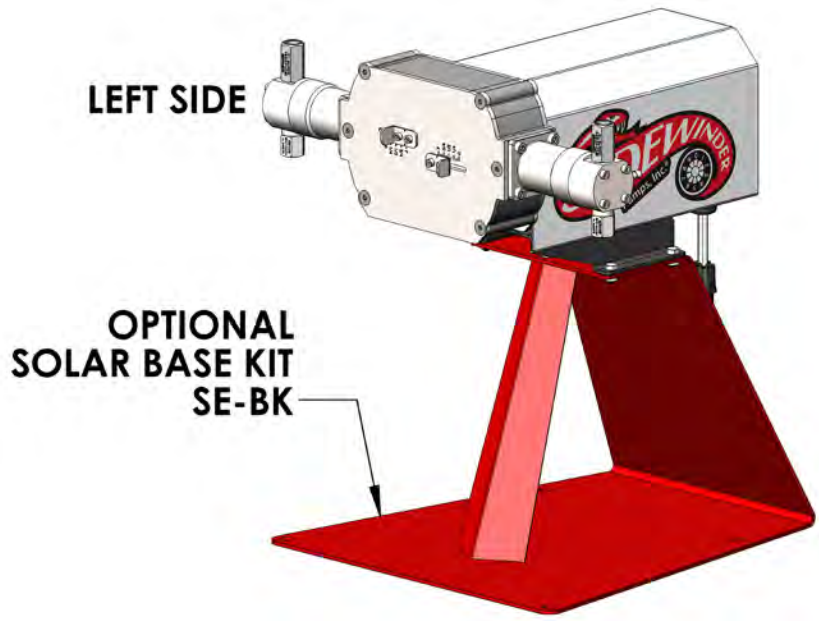

Item No.	Qty	Part Description	Part Number	
			LP VERSION	HP VERSION
1	1	Motor & Base Assembly	SE-MBA-2-A	SE-MBA-4-A
1A	1	Motor Base	SE-B-1-A	
1B	1	Motor	SE-MA-1-A	SE-MA-3-A
1C	1	Gasket, Motor to Motor Base	SE-P-1	N/A
1D	1	Rear Coverplate	SE-P-1-H-1	SE-P-1-H-2
1E	4	Screw, Motor Mount	C-001-10-1	C-002-12-1
1F	1	Terminal Block	SE-TB-1-A	
1G	2	Screw, Terminal Block Mount	C-003-10-3	
1H	1	Cord Grip	SE-CG-1-A	
1I	1	Cord Grip Nut	C-008-8-A	
1J	1	Wire Assembly, Motor	WA-C-300	
2	1	Cam Assembly	SE-CA-8	SE-CA-10
2A	1	Bearing	SE-C-1-C	
2B	1	Cam Assembly	SE-C-8-A	SE-C-10-A
2C	1	Set Screw	C-004-06	
2D	1	Cam/Bearing Lockscrew	C-015-06-2	

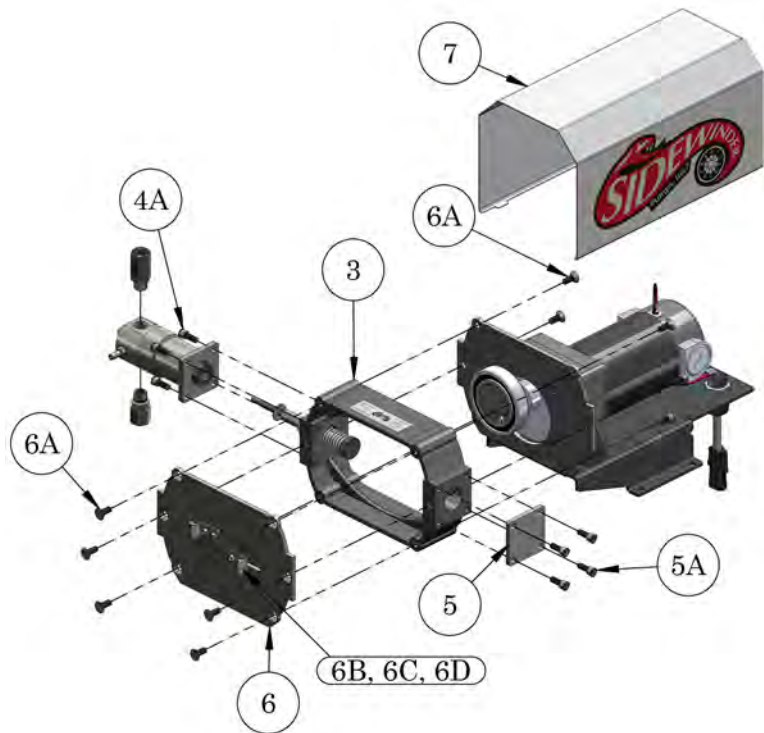

SEE NOTE 1

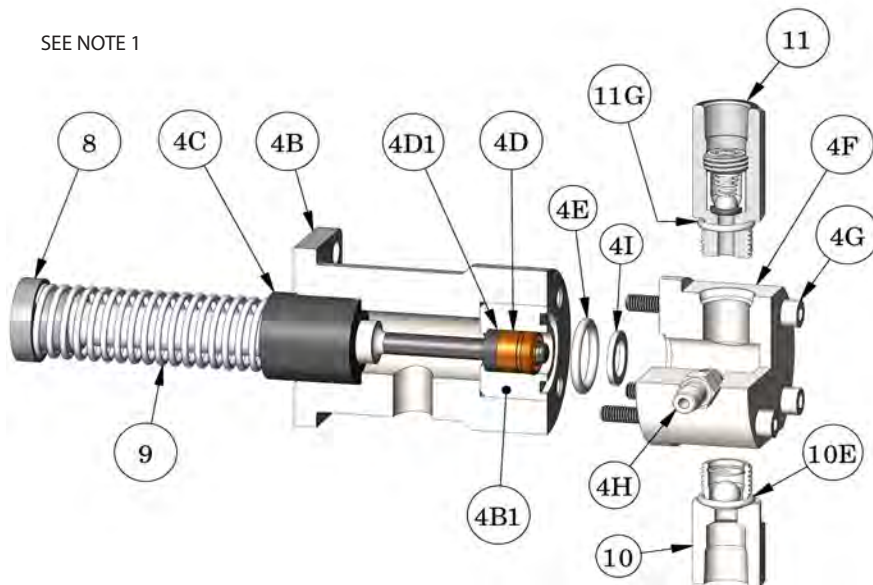

Item No.	Qty	Part Description	Part Number		
			1/4" Plunger	3/8" Plunger	1/2" Plunger
3	1	Pump Housing	SE-2-1-M		
4 *	1	Pump Assembly	SE-PA-4062	SE-PA-6062	SE-PA-8062
4A	4	Screw, Mount Tube to Pump Housing	C-007-10-3		
4B	1	Mounting Tube	SE-MT-1-B		
4B1	1	Mounting Tube Insert	SE-MTI-4-A	SE-MTI-6-A	SE-MTI-8-A
4C	1	Bushing	SE-MT-1-D		
4D	1	Plunger Seal, Teflon Carbon Filled Graphite Uniseal (STANDARD) See Sheet 6 for optional seals	18-42	18-62G	18-82
4D1	1	Backup Ring	18D-42	18D-62G	18D-82
4E	1	O-Ring, Pump Mounting Tube	C-006-116-6	C-006-119-6	C-006-119-6
4F	1	Pump Chamber	SE-PC-2-B		
4G	4	Pump Chamber Mounting Screw	C-005-28-3		
4H	1	Bleed Plug	SE-BP-1-A		
4I	1	Pump Chamber Shim	SE-SHIM-B	SE-SHIM-B	N/A
5 **	1	Simplex Coverplate	SE-SC-A		
5A	4	Screw, Simplex Coverplate	C-007-10-3		
6	1	Front Coverplate	SE-P-1-H-4		
6A	12	Screw, Coverplates to Housing	C-002-10-3		
6B	2	Stroke Limiter Control Tab	SE-SL-1-A		
6C	2	Stroke Limiter Stop	SE-SL-2-A		
6D	4	Screw, Stroke Limiter	C-021-08-3		
7	1	Motor Cover	SE-MC-A-W		
8 *	1	Plunger Assembly	SE-PLA-4-A	SE-PLA-6-A	SE-PLA-8-A
9 *	1	Return Spring	SE-RS-1-A		
10 *	1	Suction Check Valve	SE-CV-4-S-2-2-6		
10A	1	Suction Check Valve Body	SE-CV-4-S-2-A		
10B	1	Ball, Suction Check Valve	SE-CVB-5-2		
10C	1	G-Clip	22C-42-2		
N/A	-	N/A	N/A		
10E	1	O-Ring, Check Valve to pump chamber	C-006-906-6		
11 *	1	Discharge Check Valve	SE-CV-4-D-2-2-6		
11A	1	Discharge Check Valve Body	SE-CV-4-D-2-A		
11B	1	Ball, Discharge Check Valve	22B-42-2		
11C	1	Valve Seat Sleeve	23D-42-2		
11D	1	Spring, Tapered	23C-42-2		
11E	1	Spring Retainer	23E-42-2		
11F	1	O-Ring, Discharge Check Seat	23F-42		
11G	1	O-Ring, Check Valve to pump chamber	C-006-906-6		
PUMP ASSEMBLY COMPLETE (ITEMS 4, 4C - 4I, AND ITEMS (8 - 12)			SE-PAC-40622	SE-PAC-60622	SE-PAC-80622
*	Double quantities for duplex unit; Item 4 is shown in exploded view as Items 4A - 4I				
**	Simplex Unit Only				
NOTE 1	To change the plunger size, replace Items Items: 4B1, 4D, 4D1, 4E, and 8 ONLY. ATTENTION: Item 4I is not used with 1/2" plunger assemblies.				

Solar Pump Troubleshooting Guide

Problem	Possible Cause	Action
Pump Not Running	* Battery Low or Dead	* Check all electrical connections
		* Test battery and replace if necessary
		* Insure that solar panel is clean and getting full sunlight
		* Verify system design is adequate to meet autonomy requirements
	* Timer turned off	* Turn timer on
	* Blown fuse	* Check fuse located in battery/control box. Check all connections. Verify that discharge line is not blocked or a valve closed.
	* Loose Connection in Wiring	* Verify 12VDC at motor terminal. Use "RUN" option on timer to send 12VDC to motor, and verify with voltmeter
	* Motor failure	* Replace motor (if above actions do not correct issue)
Pump Runs, No fluid discharge	* Air in pump chamber	* Open bleed plug (#4H) and purge until steady flow of fluid, then close bleed plug. If ambient temperature is close to vapor point of chemical, mount or situate pump on slight angle down from the tank. 1/4" plunger pumps may require removal of discharge check valve to completely bleed all air from the pump chamber.
	* Fluid flow blocked by plugged line, closed suction valve, extremely high viscosity or lack of fluid supply	* Provide free flow of fluid to pump suction, fluid level in tank must be above level of bleed plug
	* Suction or Discharge check valve leaking	* Put pump setting gauge in test position to determine which valve is leaking. Fluid falling then rising in the gauge indicates suction check valve, fluid level remaining constant in gauge indicates discharge check
	* Chemical filter clogged	* Replace filter element or clean filter
	* Return Spring broken	* Remove front coverplate (#6). Observe pump running. If plunger (#8) not fully engaging or following the cam, stop the pump and check for broken spring or sticking plunger. Replace spring (#9) or lubricate plunger.
	* Plunger Sticking	
	* Stroke Limiter set to zero or very short stroke	* With Pump running, adjust stroke limiter (Loosen (2) #6D screws and adjust tab #6B, to allow a longer pump stroke. Always use a full stroke if possible. Reduce output by timer settings, then use stroke limiter for fine tuning pump output.
Premature Seal Failure	* Chemical Compatibility	* Check the plunger first. If plunger is scored or damaged, replace plunger and seal.
		* If seal still fails, change to different seal material.
	* Abrasive Material in Chemical	* Install suction filter
	* Bushing (#4C) worn	* Replace bushing part # SE-MT-1-B.
Chemical leakage	* Damaged or leaking suction line, discharge line or seal failure	* Prior to repair:
		* Open the control/battery box and turn the timer to the "OFF" position.
		* Close Isolation ball valve "B" between pump setting gauge and chemical tank (see Diagram 1 on page 2)
		* Close isolation ball valve "A" between pump and pump setting gauge (see Diagram 1 on page 2)

NOTE: Item numbers referenced in the troubleshooting guide are in the Pump Breakdown chart provided in this document.

Manufacturer Disclaimer

Manufacturer recommends the use of 316SS seamless tubing rated for the maximum discharge pressure of the specific pump model being used. DO NOT USE poly tubing, copper tubing, and/or seamed tubing as a discharge line. Use of incorrect material may result in discharge line failure leading to personal injury, death, and/or compromise to intended injection objectives. For Safety Purposes and Good Engineering Practice, the manufacturer recommends placement of a properly sized Pressure Relief Valve (PRV) / Pressure Safety Valve (PSV) on the pump discharge line at the pump, with the relief line plumbed back to the chemical tank.

PARTS LIST: MAIN PUMP ASSEMBLY

Pump part number structure:

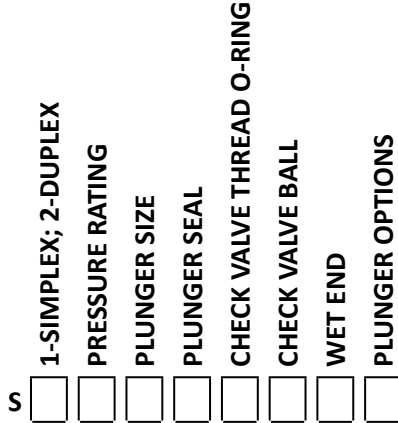

ITEM	CODE	DESCRIPTION
PRESSURE RATING	2	LP VERSION (UP TO 2000 PSI MAX)
	4	HP VERSION (UP TO 5000 PSI MAX)
PLUNGER SIZE	4	1/4"
	6	3/8"
	8	1/2"
PLUNGER SEAL OPTIONS	0	TEFLON GRAPHITE UNISEAL
	1	TECHNO UNISEAL (POLYIMIDE)
	4	TEFLON UNISEAL
	4A	TEFLON UNISEAL W/ AFLAS O-RING INSERT
	4B	TEFLON UNISEAL W/ BUNA O-RING INSERT
	4V	TEFLON UNISEAL W/ VITON O-RING INSERT
	8	POLYBLEND UNISEAL
	8V	POLYBLEND UNISEAL W / VITON INSERT
	9	CUSTOMER SPECIFIED
V	VITON/CARBON TEFLON UNISEAL	
CHECK VALVE / BODY SEAL OPTIONS	2	VITON O-RING
	3	BUNA O-RING
	5	CHEMRAZ O-RING
	6	HITEC O-RING (AFLAS)
	7	VIRGIN TEFLON O-RING
CHECK VALVE BALL OPTIONS	2	316 STAINLESS STEEL
	4	CERAMIC
WET END	2	316 STAINLESS STEEL
PLUNGER OPTIONS		LEAVE BLANK FOR STD. CERAMIC COATED
	0	17-4 STAINLESS STEEL



Chemical Metering Pumps
www.sidewinderpumps.com

TABLE 1.1: APPROXIMATE QUARTS PER DAY AT THE VARIOUS RUN TIMES AND CYCLES/MINUTE USING A SIMPLEX PUMP (MULTIPLY X 2 FOR DUPLEX OPERATION)

1/4" PLUNGER - SIMPLEX PUMP (MULTIPLY X 2 FOR DUPLEX OPERATION)	SHADED AREAS ARE OUTSIDE SIDEWINDER RECOMMENDED OPERATIONAL RANGE (CALL FACTORY)	RUN TIME (SEC)	"CYC" (NUMBER OF CYCLES / MINUTE) NOTE: SIDEWINDER RECOMMENDS THE MAXIMUM FLOW RATE & RUN TIME BE NO MORE THAN 40% OF MAXIMUM CAPACITY																													
			1	2	3	4	5	6	7	8	9	10	11	12	13	14	15	16	17	18	19	20	21	22	23	24	25	26	27	28	29	30
			0.5	0.6	1.2	1.8	2.4	3.1	3.7	4.3	4.9	5.5	6.1	6.7	7.3	7.9	8.6	9.2	9.8	10.4	11.0	11.6	12.2	12.8	13.4	14.1	14.7	15.3	15.9	16.5	17.1	17.7
1.0	1.2	2.4	3.7	4.9	6.1	7.3	8.6	9.8	11.0	12.2	13.4	14.7	15.9	17.1	18.3	19.5	20.8	22.0	23.2	24.4	25.7	26.9	28.1	29.3	30.5	31.8	33.0	34.2	35.4	36.7		
1.5	1.8	3.7	5.5	7.3	9.2	11.0	12.8	14.7	16.5	18.3	20.2	22.0	23.8	25.7	27.5	29.3	31.2	33.0	34.8	36.7	38.5	40.3	42.2	44.0	45.8	47.7	49.5	51.3	53.1	55.0		
2.0	2.4	4.9	7.3	9.8	12.2	14.7	17.1	19.5	22.0	24.4	26.9	29.3	31.8	34.2	36.7	39.1	41.5	44.0	46.4	48.9	51.3	53.8	56.2	58.6	61.1	63.5	66.0	68.4	70.9	73.3		
2.5	3.1	6.1	9.2	12.2	15.3	18.3	21.4	24.4	27.5	30.5	33.6	36.7	39.7	42.8	45.8	48.9	51.9	55.0	58.0	61.1	64.1	67.2	70.3	73.3	N/A	N/A	N/A	N/A	N/A	N/A		
3.0	3.7	7.3	11.0	14.7	18.3	22.0	25.7	29.3	33.0	36.7	40.3	44.0	47.7	51.3	55.0	58.6	62.3	66.0	69.6	73.3	N/A	N/A	N/A	N/A	N/A	N/A	N/A	N/A	N/A	N/A		
3.5	4.3	8.6	12.8	17.1	21.4	25.7	29.9	34.2	38.5	42.8	47.0	51.3	55.6	59.9	64.1	68.4	72.7	N/A	N/A	N/A	N/A	N/A	N/A	N/A	N/A	N/A	N/A	N/A	N/A	N/A		
4.0	4.9	9.8	14.7	19.5	24.4	29.3	34.2	39.1	44.0	48.9	53.8	58.6	63.5	68.4	73.3	N/A	N/A	N/A	N/A	N/A	N/A	N/A	N/A	N/A	N/A	N/A	N/A	N/A	N/A	N/A		
4.5	5.5	11.0	16.5	22.0	27.5	33.0	38.5	44.0	49.5	55.0	60.5	66.0	71.5	N/A	N/A	N/A	N/A	N/A	N/A	N/A	N/A	N/A	N/A	N/A	N/A	N/A	N/A	N/A	N/A	N/A		
5.0	6.1	12.2	18.3	24.4	30.5	36.7	42.8	48.9	55.0	61.1	67.2	73.3	N/A	N/A	N/A	N/A	N/A	N/A	N/A	N/A	N/A	N/A	N/A	N/A	N/A	N/A	N/A	N/A	N/A	N/A		
5.5	6.7	13.4	20.2	26.9	33.6	40.3	47.0	53.8	60.5	67.2	73.9	N/A	N/A	N/A	N/A	N/A	N/A	N/A	N/A	N/A	N/A	N/A	N/A	N/A	N/A	N/A	N/A	N/A	N/A	N/A		
6.0	7.3	14.7	22.0	29.3	36.7	44.0	51.3	58.6	66.0	73.3	N/A	N/A	N/A	N/A	N/A	N/A	N/A	N/A	N/A	N/A	N/A	N/A	N/A	N/A	N/A	N/A	N/A	N/A	N/A	N/A		
6.5	7.9	15.9	23.8	31.8	39.7	47.7	55.6	63.5	71.5	N/A	N/A	N/A	N/A	N/A	N/A	N/A	N/A	N/A	N/A	N/A	N/A	N/A	N/A	N/A	N/A	N/A	N/A	N/A	N/A	N/A		
7.0	8.6	17.1	25.7	34.2	42.8	51.3	59.9	68.4	N/A	N/A	N/A	N/A	N/A	N/A	N/A	N/A	N/A	N/A	N/A	N/A	N/A	N/A	N/A	N/A	N/A	N/A	N/A	N/A	N/A	N/A		
7.5	9.2	18.3	27.5	36.7	45.8	55.0	64.1	73.3	N/A	N/A	N/A	N/A	N/A	N/A	N/A	N/A	N/A	N/A	N/A	N/A	N/A	N/A	N/A	N/A	N/A	N/A	N/A	N/A	N/A	N/A		
8.0	9.8	19.5	29.3	39.1	48.9	58.6	68.4	N/A	N/A	N/A	N/A	N/A	N/A	N/A	N/A	N/A	N/A	N/A	N/A	N/A	N/A	N/A	N/A	N/A	N/A	N/A	N/A	N/A	N/A	N/A		
8.5	10.4	20.8	31.2	41.5	51.9	62.3	72.7	N/A	N/A	N/A	N/A	N/A	N/A	N/A	N/A	N/A	N/A	N/A	N/A	N/A	N/A	N/A	N/A	N/A	N/A	N/A	N/A	N/A	N/A	N/A		
9.0	11.0	22.0	33.0	44.0	55.0	66.0	N/A	N/A	N/A	N/A	N/A	N/A	N/A	N/A	N/A	N/A	N/A	N/A	N/A	N/A	N/A	N/A	N/A	N/A	N/A	N/A	N/A	N/A	N/A	N/A		
9.5	11.6	23.2	34.8	46.4	58.0	69.6	N/A	N/A	N/A	N/A	N/A	N/A	N/A	N/A	N/A	N/A	N/A	N/A	N/A	N/A	N/A	N/A	N/A	N/A	N/A	N/A	N/A	N/A	N/A	N/A		
10.0	12.2	24.4	36.7	48.9	61.1	73.3	N/A	N/A	N/A	N/A	N/A	N/A	N/A	N/A	N/A	N/A	N/A	N/A	N/A	N/A	N/A	N/A	N/A	N/A	N/A	N/A	N/A	N/A	N/A	N/A		
		CYC (NUMBER OF CYCLES / MINUTE)																														
		31	32	33	34	35	36	37	38	39	40	41	42	43	44	45	46	47	48	49	50	51	52	53	54	55	56	57	58	59	60	
0.5	18.9	19.5	20.2	20.8	21.4	22.0	22.6	23.2	23.8	24.4	25.0	25.7	26.3	26.9	27.5	28.1	28.7	29.3	29.9	30.5	31.2	31.8	32.4	33.0	33.6	34.2	34.8	35.4	36.0	36.7		
1.0	37.9	39.1	40.3	41.5	42.8	44.0	45.2	46.4	47.7	48.9	50.1	51.3	52.5	53.8	55.0	56.2	57.4	58.6	59.9	61.1	62.3	63.5	64.8	66.0	67.2	68.4	69.6	70.9	72.1	73.3		
1.5	56.8	58.6	60.5	62.3	64.1	66.0	67.8	69.6	71.5	73.3	N/A	N/A	N/A	N/A	N/A	N/A	N/A	N/A	N/A	N/A	N/A	N/A	N/A	N/A	N/A	N/A	N/A	N/A	N/A	N/A		
2.0	CONTINUED FROM ABOVE "CYC" VALUES 31 AND GREATER ARE NOT AVAILABLE WITH RUN TIMES 2.0 SECONDS AND GREATER																															

MAXIMUM PRESSURE - LP = 2000 PSI, HP = 5000PSI



Chemical Metering Pumps
www.sidewinderpumps.com

TABLE 1.2: APPROXIMATE QUARTS PER DAY AT THE VARIOUS RUN TIMES AND CYCLES/MINUTE USING A SIMPLEX PUMP (MULTIPLY X 2 FOR DUPLEX OPERATION)

RUN TIME (SEC)	"CYC" (NUMBER OF CYCLES / MINUTE) NOTE: SIDEWINDER RECOMMENDS THE MAXIMUM FLOW RATE & RUN TIME BE NO MORE THAN 40% OF MAXIMUM CAPACITY																														
	1	2	3	4	5	6	7	8	9	10	11	12	13	14	15	16	17	18	19	20	21	22	23	24	25	26	27	28	29	30	
0.5	1.4	2.7	4.1	5.5	6.9	8.2	9.6	11.0	12.3	13.7	15.1	16.5	17.8	19.2	20.6	21.9	23.3	24.7	26.1	27.4	28.8	30.2	31.5	32.9	34.3	35.7	37.0	38.4	39.8	41.1	
1.0	2.7	5.5	8.2	11.0	13.7	16.5	19.2	21.9	24.7	27.4	30.2	32.9	35.7	38.4	41.1	43.9	46.6	49.4	52.1	54.9	57.6	60.3	63.1	65.8	68.6	71.3	74.1	76.8	79.5	82.3	
1.5	4.1	8.2	12.3	16.5	20.6	24.7	28.8	32.9	37.0	41.1	45.3	49.4	53.5	57.6	61.7	65.8	69.9	74.1	78.2	82.3	86.4	90.5	94.6	98.7	102.9	107.0	111.1	115.2	119.3	123.4	
2.0	5.5	11.0	16.5	21.9	27.4	32.9	38.4	43.9	49.4	54.9	60.3	65.8	71.3	76.8	82.3	87.8	93.3	98.7	104.2	109.7	115.2	120.7	126.2	131.7	137.1	142.6	148.1	153.6	159.1	164.6	
2.5	6.9	13.7	20.6	27.4	34.3	41.1	48.0	54.9	61.7	68.6	75.4	82.3	89.1	96.0	102.9	109.7	116.6	123.4	130.3	137.1	144.0	150.9	157.7	164.6	N/A	N/A	N/A	N/A	N/A	N/A	
3.0	8.2	16.5	24.7	32.9	41.1	49.4	57.6	65.8	74.1	82.3	90.5	98.7	107.0	115.2	123.4	131.7	139.9	148.1	156.3	164.6	N/A	N/A	N/A	N/A	N/A	N/A	N/A	N/A	N/A	N/A	N/A
3.5	9.6	19.2	28.8	38.4	48.0	57.6	67.2	76.8	86.4	96.0	105.6	115.2	124.8	134.4	144.0	153.6	163.2	N/A	N/A	N/A	N/A	N/A	N/A	N/A	N/A	N/A	N/A	N/A	N/A	N/A	N/A
4.0	11.0	21.9	32.9	43.9	54.9	65.8	76.8	87.8	98.7	109.7	120.7	131.7	142.6	153.6	164.6	N/A	N/A	N/A	N/A	N/A	N/A	N/A	N/A	N/A	N/A	N/A	N/A	N/A	N/A	N/A	N/A
4.5	12.3	24.7	37.0	49.4	61.7	74.1	86.4	98.7	111.1	123.4	135.8	148.1	160.5	N/A	N/A	N/A	N/A	N/A	N/A	N/A	N/A	N/A	N/A	N/A	N/A	N/A	N/A	N/A	N/A	N/A	N/A
5.0	13.7	27.4	41.1	54.9	68.6	82.3	96.0	109.7	123.4	137.1	150.9	164.6	N/A	N/A	N/A	N/A	N/A	N/A	N/A	N/A	N/A	N/A	N/A	N/A	N/A	N/A	N/A	N/A	N/A	N/A	N/A
5.5	15.1	30.2	45.3	60.3	75.4	90.5	105.6	120.7	135.8	150.9	165.9	N/A	N/A	N/A	N/A	N/A	N/A	N/A	N/A	N/A	N/A	N/A	N/A	N/A	N/A	N/A	N/A	N/A	N/A	N/A	N/A
6.0	16.5	32.9	49.4	65.8	82.3	98.7	115.2	131.7	148.1	164.6	N/A	N/A	N/A	N/A	N/A	N/A	N/A	N/A	N/A	N/A	N/A	N/A	N/A	N/A	N/A	N/A	N/A	N/A	N/A	N/A	N/A
6.5	17.8	35.7	53.5	71.3	89.1	107.0	124.8	142.6	160.5	N/A	N/A	N/A	N/A	N/A	N/A	N/A	N/A	N/A	N/A	N/A	N/A	N/A	N/A	N/A	N/A	N/A	N/A	N/A	N/A	N/A	N/A
7.0	19.2	38.4	57.6	76.8	96.0	115.2	134.4	153.6	N/A	N/A	N/A	N/A	N/A	N/A	N/A	N/A	N/A	N/A	N/A	N/A	N/A	N/A	N/A	N/A	N/A	N/A	N/A	N/A	N/A	N/A	N/A
7.5	20.6	41.1	61.7	82.3	102.9	123.4	144.0	164.6	N/A	N/A	N/A	N/A	N/A	N/A	N/A	N/A	N/A	N/A	N/A	N/A	N/A	N/A	N/A	N/A	N/A	N/A	N/A	N/A	N/A	N/A	N/A
8.0	21.9	43.9	65.8	87.8	109.7	131.7	153.6	N/A	N/A	N/A	N/A	N/A	N/A	N/A	N/A	N/A	N/A	N/A	N/A	N/A	N/A	N/A	N/A	N/A	N/A	N/A	N/A	N/A	N/A	N/A	N/A
8.5	23.3	46.6	69.9	93.3	116.6	139.9	163.2	N/A	N/A	N/A	N/A	N/A	N/A	N/A	N/A	N/A	N/A	N/A	N/A	N/A	N/A	N/A	N/A	N/A	N/A	N/A	N/A	N/A	N/A	N/A	N/A
9.0	24.7	49.4	74.1	98.7	123.4	148.1	N/A	N/A	N/A	N/A	N/A	N/A	N/A	N/A	N/A	N/A	N/A	N/A	N/A	N/A	N/A	N/A	N/A	N/A	N/A	N/A	N/A	N/A	N/A	N/A	N/A
9.5	26.1	52.1	78.2	104.2	130.3	156.3	N/A	N/A	N/A	N/A	N/A	N/A	N/A	N/A	N/A	N/A	N/A	N/A	N/A	N/A	N/A	N/A	N/A	N/A	N/A	N/A	N/A	N/A	N/A	N/A	N/A
10.0	27.4	54.9	82.3	109.7	137.1	164.6	N/A	N/A	N/A	N/A	N/A	N/A	N/A	N/A	N/A	N/A	N/A	N/A	N/A	N/A	N/A	N/A	N/A	N/A	N/A	N/A	N/A	N/A	N/A	N/A	N/A
RUN TIME (SEC)	CYC (NUMBER OF CYCLES / MINUTE)																														
	31	32	33	34	35	36	37	38	39	40	41	42	43	44	45	46	47	48	49	50	51	52	53	54	55	56	57	58	59	60	
0.5	42.5	43.9	45.3	46.6	48.0	49.4	50.7	52.1	53.5	54.9	56.2	57.6	59.0	60.3	61.7	63.1	64.5	65.8	67.2	68.6	69.9	71.3	72.7	74.1	75.4	76.8	78.2	79.5	80.9	82.3	
1.0	85.0	87.8	90.5	93.3	96.0	98.7	101.5	104.2	107.0	109.7	112.5	115.2	117.9	120.7	123.4	126.2	128.9	131.7	134.4	137.1	139.9	142.6	145.4	148.1	150.9	153.6	156.3	159.1	161.8	164.6	
1.5	127.5	131.7	135.8	139.9	144.0	148.1	152.2	156.3	160.5	164.6	N/A	N/A	N/A	N/A	N/A	N/A	N/A	N/A	N/A	N/A	N/A	N/A	N/A	N/A	N/A	N/A	N/A	N/A	N/A	N/A	N/A
2.0	CONTINUED FROM ABOVE "CYC" VALUES 31 AND GREATER ARE NOT AVAILABLE WITH RUN TIMES 2.0 SECONDS AND GREATER																														

MAXIMUM PRESSURE - LP = 850 PSI, HP = 2500PSI



Chemical Metering Pumps
www.sidewinderpumps.com

TABLE 1.3: APPROXIMATE QUARTS PER DAY AT THE VARIOUS RUN TIMES AND CYCLES/MINUTE USING A SIMPLEX PUMP (MULTIPLY X 2 FOR DUPLEX OPERATION)

RUN TIME (SEC)	"CYC" (NUMBER OF CYCLES / MINUTE) NOTE: SIDEWINDER RECOMMENDS THE MAXIMUM FLOW RATE & RUN TIME BE NO MORE THAN 40% OF MAXIMUM CAPACITY																														
	1	2	3	4	5	6	7	8	9	10	11	12	13	14	15	16	17	18	19	20	21	22	23	24	25	26	27	28	29	30	
0.5	2.4	4.9	7.3	9.8	12.2	14.7	17.1	19.5	22.0	24.4	26.9	29.3	31.8	34.2	36.7	39.1	41.5	44.0	46.4	48.9	51.3	53.8	56.2	58.6	61.1	63.5	66.0	68.4	70.9	73.3	
1.0	4.9	9.8	14.7	19.5	24.4	29.3	34.2	39.1	44.0	48.9	53.8	58.6	63.5	68.4	73.3	78.2	83.1	88.0	92.9	97.7	102.6	107.5	112.4	117.3	122.2	127.1	132.0	136.8	141.7	146.6	
1.5	7.3	14.7	22.0	29.3	36.7	44.0	51.3	58.6	66.0	73.3	80.6	88.0	95.3	102.6	110.0	117.3	124.6	132.0	139.3	146.6	153.9	161.3	168.6	175.9	183.3	190.6	197.9	205.3	212.6	219.9	
2.0	9.8	19.5	29.3	39.1	48.9	58.6	68.4	78.2	88.0	97.7	107.5	117.3	127.1	136.8	146.6	156.4	166.2	175.9	185.7	195.5	205.3	215.0	224.8	234.6	244.4	254.1	263.9	273.7	283.5	293.2	
2.5	12.2	24.4	36.7	48.9	61.1	73.3	85.5	97.7	110.0	122.2	134.4	146.6	158.8	171.1	183.3	195.5	207.7	219.9	232.1	244.4	256.6	268.8	281.0	293.2	N/A	N/A	N/A	N/A	N/A	N/A	
3.0	14.7	29.3	44.0	58.6	73.3	88.0	102.6	117.3	132.0	146.6	161.3	175.9	190.6	205.3	219.9	234.6	249.3	263.9	278.6	293.2	N/A	N/A	N/A	N/A	N/A	N/A	N/A	N/A	N/A	N/A	N/A
3.5	17.1	34.2	51.3	68.4	85.5	102.6	119.7	136.8	153.9	171.1	188.2	205.3	222.4	239.5	256.6	273.7	290.8	N/A	N/A	N/A	N/A	N/A	N/A	N/A	N/A	N/A	N/A	N/A	N/A	N/A	N/A
4.0	19.5	39.1	58.6	78.2	97.7	117.3	136.8	156.4	175.9	195.5	215.0	234.6	254.1	273.7	293.2	N/A	N/A	N/A	N/A	N/A	N/A	N/A	N/A	N/A	N/A	N/A	N/A	N/A	N/A	N/A	N/A
4.5	22.0	44.0	66.0	88.0	110.0	132.0	153.9	175.9	197.9	219.9	241.9	263.9	285.9	N/A	N/A	N/A	N/A	N/A	N/A	N/A	N/A	N/A	N/A	N/A	N/A	N/A	N/A	N/A	N/A	N/A	N/A
5.0	24.4	48.9	73.3	97.7	122.2	146.6	171.1	195.5	219.9	244.4	268.8	293.2	N/A	N/A	N/A	N/A	N/A	N/A	N/A	N/A	N/A	N/A	N/A	N/A	N/A	N/A	N/A	N/A	N/A	N/A	N/A
5.5	26.9	53.8	80.6	107.5	134.4	161.3	188.2	215.0	241.9	268.8	295.7	N/A	N/A	N/A	N/A	N/A	N/A	N/A	N/A	N/A	N/A	N/A	N/A	N/A	N/A	N/A	N/A	N/A	N/A	N/A	N/A
6.0	29.3	58.6	88.0	117.3	146.6	175.9	205.3	234.6	263.9	293.2	N/A	N/A	N/A	N/A	N/A	N/A	N/A	N/A	N/A	N/A	N/A	N/A	N/A	N/A	N/A	N/A	N/A	N/A	N/A	N/A	N/A
6.5	31.8	63.5	95.3	127.1	158.8	190.6	222.4	254.1	285.9	N/A	N/A	N/A	N/A	N/A	N/A	N/A	N/A	N/A	N/A	N/A	N/A	N/A	N/A	N/A	N/A	N/A	N/A	N/A	N/A	N/A	N/A
7.0	34.2	68.4	102.6	136.8	171.1	205.3	239.5	273.7	N/A	N/A	N/A	N/A	N/A	N/A	N/A	N/A	N/A	N/A	N/A	N/A	N/A	N/A	N/A	N/A	N/A	N/A	N/A	N/A	N/A	N/A	N/A
7.5	36.7	73.3	110.0	146.6	183.3	219.9	256.6	293.2	N/A	N/A	N/A	N/A	N/A	N/A	N/A	N/A	N/A	N/A	N/A	N/A	N/A	N/A	N/A	N/A	N/A	N/A	N/A	N/A	N/A	N/A	N/A
8.0	39.1	78.2	117.3	156.4	195.5	234.6	273.7	N/A	N/A	N/A	N/A	N/A	N/A	N/A	N/A	N/A	N/A	N/A	N/A	N/A	N/A	N/A	N/A	N/A	N/A	N/A	N/A	N/A	N/A	N/A	N/A
8.5	41.5	83.1	124.6	166.2	207.7	249.3	290.8	N/A	N/A	N/A	N/A	N/A	N/A	N/A	N/A	N/A	N/A	N/A	N/A	N/A	N/A	N/A	N/A	N/A	N/A	N/A	N/A	N/A	N/A	N/A	N/A
9.0	44.0	88.0	132.0	175.9	219.9	263.9	N/A	N/A	N/A	N/A	N/A	N/A	N/A	N/A	N/A	N/A	N/A	N/A	N/A	N/A	N/A	N/A	N/A	N/A	N/A	N/A	N/A	N/A	N/A	N/A	N/A
9.5	46.4	92.9	139.3	185.7	232.1	278.6	N/A	N/A	N/A	N/A	N/A	N/A	N/A	N/A	N/A	N/A	N/A	N/A	N/A	N/A	N/A	N/A	N/A	N/A	N/A	N/A	N/A	N/A	N/A	N/A	N/A
10.0	48.9	97.7	146.6	195.5	244.4	293.2	N/A	N/A	N/A	N/A	N/A	N/A	N/A	N/A	N/A	N/A	N/A	N/A	N/A	N/A	N/A	N/A	N/A	N/A	N/A	N/A	N/A	N/A	N/A	N/A	N/A
RUN TIME (SEC)	CYC (NUMBER OF CYCLES / MINUTE)																														
	31	32	33	34	35	36	37	38	39	40	41	42	43	44	45	46	47	48	49	50	51	52	53	54	55	56	57	58	59	60	
0.5	75.8	78.2	80.6	83.1	85.5	88.0	90.4	92.9	95.3	97.7	100.2	102.6	105.1	107.5	110.0	112.4	114.9	117.3	119.7	122.2	124.6	127.1	129.5	132.0	134.4	136.8	139.3	141.7	144.2	146.6	
1.0	151.5	156.4	161.3	166.2	171.1	175.9	180.8	185.7	190.6	195.5	200.4	205.3	210.2	215.0	219.9	224.8	229.7	234.6	239.5	244.4	249.3	254.1	259.0	263.9	268.8	273.7	278.6	283.5	288.3	293.2	
1.5	227.3	234.6	241.9	249.3	256.6	263.9	271.2	278.6	285.9	293.2	N/A	N/A	N/A	N/A	N/A	N/A	N/A	N/A	N/A	N/A	N/A	N/A	N/A	N/A	N/A	N/A	N/A	N/A	N/A	N/A	N/A
2.0	CONTINUED FROM ABOVE "CYC" VALUES 31 AND GREATER ARE NOT AVAILABLE WITH RUN TIMES 2.0 SECONDS AND GREATER																														

MAXIMUM PRESSURE - LP = 500 PSI, HP = 1250PSI



There ain't no better pump

"Dedicated to providing state of the art metering solutions for all your chemical treatment needs."

Sidewinder Pumps, Inc.
107 Commission Blvd., Lafayette, Louisiana 70508
P.O. Box 80769, Lafayette, LA 70598-0769

(337) 235-9838 / Fax (337) 235-9852 • www.sidewinderpumps.com • info@sidewinderpumps.com