



MODELS 44C, 64D, & 84C

Pneumatic Powered Plunger Pump - Suggested Installation and Operational Instructions

Contact Sidewinder Pumps Inc @ 337-235-9838 or PO Box 80769, Lafayette, LA 70598-0769 www.sidewinderpumps.com

See suggested Pump Installation & System Setup Diagram and Pump Breakdown, inside this document.

- 1) When installing pump, manufacturer recommends the use of 316SS seamless tubing rated for the maximum discharge pressure of the specific pump model being used. DO NOT USE poly tubing, copper tubing, and/or seamed tubing as a discharge line. Use of incorrect material may result in discharge line failure leading to personal injury, death, and/or compromise to intended injection objectives. For Safety Purposes and Good Engineering Practice, the manufacturer recommends placement of a properly sized Pressure Relief Valve (PRV) / Pressure Safety Valve (PSV) on the pump discharge line at the pump, with the relief line plumbed back to the chemical tank (#7).
- 2) Install pump setting gauge (#9) onto chemical tank (#7), with an isolation ball valve (#8) between tank and gauge.
- 3) Install pump with suction filter (#11) with isolation ball valve (#8) between pump and pump setting gauge (#9).
- 4) A regulator (#2) should be installed in the air/gas supply line to provide correct supply of air/gas pressure. Connect air/gas supply line from regulator (#2) to the pump supply inlet using 1/4" NPT tee with 0-150 PSI gauge. An isolation ball valve (#5) should be installed between air/gas regulator (#2) and the pump. Use minimum of 3/8 inch diameter tubing (#3) with a maximum distance of 10 feet from regulator to the pump. If longer distance is required or multiple pumps are run off same supply line, a volume bottle (#4) should be installed within 5 feet of the pump(s).
- 5) If the air/gas supply is "wet", a volume bottle (#4) with a drain and filter should be installed in between the regulator (#2) and pump(s) as close as possible to the pump(s). If the air/gas supply is extremely "wet" a scrubber (#1) should be installed on the main flow line with regulator taking its supply from the scrubber.
- 6) Set the regulator (#2) to required pressure. See Pump Selection Guide and Performance Chart
- 7) Connect discharge line to the 1/4 inch NPT discharge check valve. For good safety practice an in-line check valve (Sidewinder part number LC-4S) (#10) should be installed on the discharge line at the injection point.
- 8) If natural gas is used as the supply gas, pump exhaust should be vented via the 1/8" NPT threaded port on the control valve body (#53) to safe disposal area or non pressurized disposal device
- 9) Open bleeder valve (#20 Pump Breakdown) until air removed from pump chamber. Isolate pump setting gauge (#9) from tank. Open air/gas isolation valve (#5) to pump. Run pump following directions on pump setting gauge to determine flow rate.
- 10) Adjust speed of pump by rotating dial (#31 Pump Breakdown), clockwise to decrease dial number of strokes per minute, counter clockwise to increase number of strokes per minute. Further volume control can be set by varying the length of the piston/plunger stroke with the stroke adjuster (#1 Pump Breakdown).
- 11) Reset isolation ball valves (#8) so pump takes chemical direct from tank (#7).

Pump Repair or Emergency Shutdown Instructions

- 1) To perform repairs to the pump or to the pump setting gauge, close the air/gas supply isolation ball valve (#5), close both isolation ball valves (#8) between tank (#7) & gauge (#9) and pump & gauge (#9). Remove component(s) to be repaired. After repair, reinstall component(s). Open isolation ball valve (#8) between tank (#7) and gauge (#9), check for leaks. Open isolation ball valve (#8) between pump and gauge (#9), check for leaks. Perform steps 8 thru 10 above.
- 2) **In event of an emergency the following steps are to be done in the following order**
 - i) **Close air/gas supply isolation ball valve (#5)**
 - ii) **Close isolation ball valve #8 between pump setting gauge (#9) and chemical tank (#7)**
 - iii) **Close isolation ball valve #8 between pump and pump setting gauge (#9)**

Parts List / Models 44C, 64D, & 84C

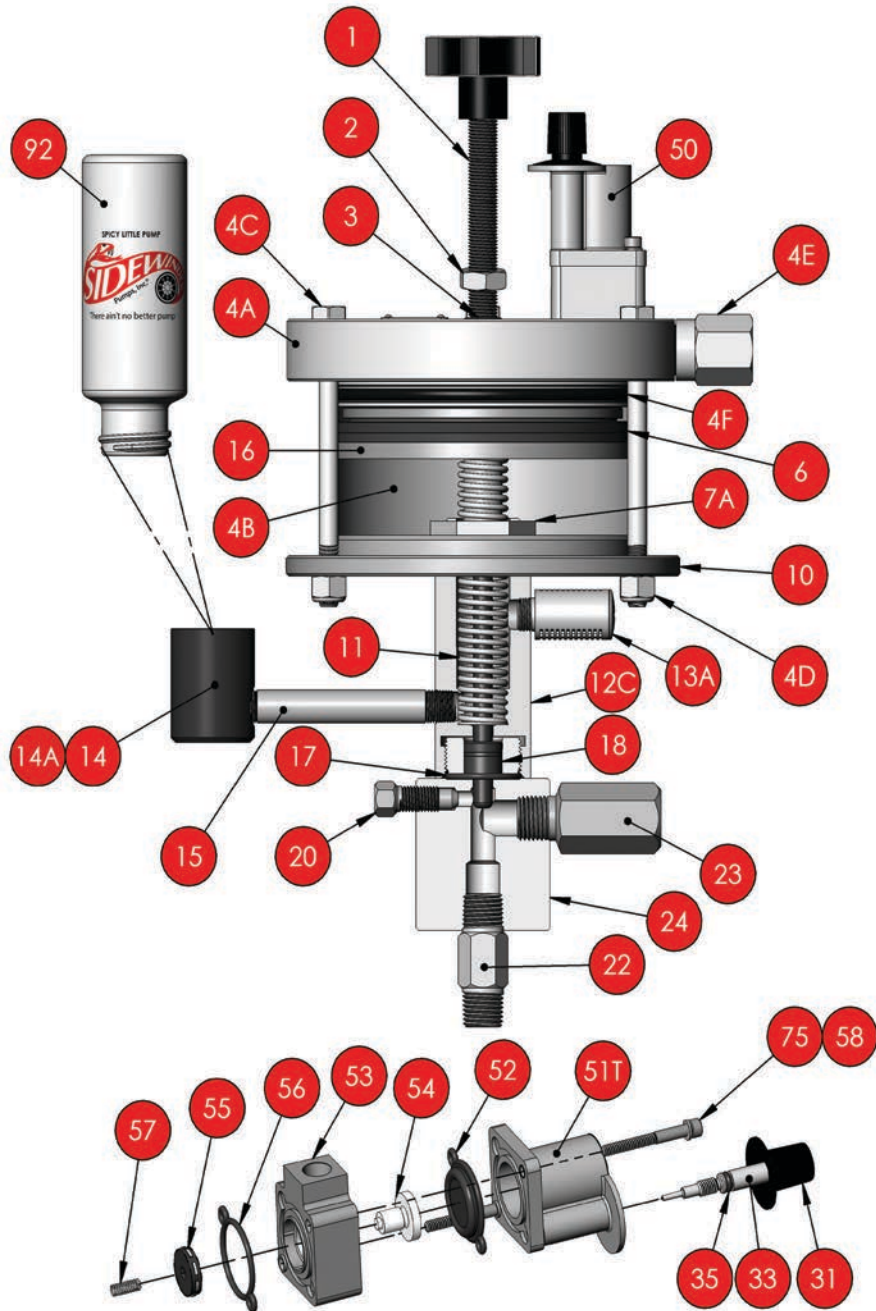

Item No.	Qty. Req'd	Part Description	Part Number		
			MODEL 44C	MODEL 64D	MODEL 84C
1	1	Stroke Adjuster	1-42	1-42	1-42
2	1	Locknut-Stroke Adjuster	2-42	2-42	2-42
3*#	1	Seal-Stroke Adjuster	3-42	3-42	3-42
4A	1	4.00" Powerhead Cap	4A-44-2	4A-44-2	4A-44-2
4B	1	Powerhead Cyclinder	4B-44-2	4B-44-2	4B-44-2
4C	6	Powerhead Tie Bolt	4C-44-2	4C-44-2	4C-44-2
4D	6	Powerhead Tie Bolt Nut	4D-44-2	4D-44-2	4D-44-2
4E	1	Powerhead Inlet Connector Fitting	4E-44-2	4E-44-22	4E-44-2
4F*#	1	Powerhead Cap O-Ring	4F-44	4F-44	4F-44
6*#	1	U-Cup (Viton Available-See Note 6*)	6-44	6-44	6-44
7A	1	Mounting Tube Locknut	7A-42	7A-42	7A-42
10#	1	Mounting Flange	10-44-B	10-44-B	10-44-B
11*#	1	Return Spring (Spring options see note 11b)	11-44	11-44	11-44
12C	1	Mounting Tube	12C-42	12C-62	12C-82
13A	1	Vent	13A-42	13A-42	13A-42
14	1	Lube Body	14-42	14-42	14-42
14A*	1	Lube Body O-Ring	14A-42	14A-42	14A-42
15	1	Lube Tube	15-43	15-43	15-43
16*	1	Piston-Plunger - 17-4 SS	16-44	16-64	16-84
		Piston-Plunger - 316 SS	16-44-2	16-64-2	16-84-2
		Piston-Plunger - 440 SS	16-44-3	16-64-3	16-84-3
		Piston-Plunger - Ceramic	16-44-4	16-64-4	16-84-4
		Piston-Plunger - Hastelloy	16-44-5	16-64-5	16-84-5
		Piston-Plunger - Titanium	16-44-6	16-64-6	16-84-6
		Piston-Plunger - 440C SS w/ Chrome Plating	16-44-7	16-44-7	16-44-7
		Piston-Plunger - 440C SS w/ Electroless Nickel Plating	16-44-8	16-64-8	16-84-8
		Customer Specified Special	16-44-9	16-64-9	16-84-9
17*#	1	O-Ring Mounting Tube	17-42	17-42	17-42
18*#	1	Plunger Seal - Teflon Carbon Filled Graphite Uniseal	18-42	18-62	18-82
		Plunger Seal - Techno Uniseal	18-42-1	18-62-1	18-82-1
		Plunger Seal - Viton O-Ring	18-42-2	18-62-2	18-82-2
		Plunger Seal - Buna O-Ring	18-42-3	18-62-3	18-82-3
		Plunger Seal - Virgin Teflon Uniseal	18-42-4	18-62-4	18-82-4
		Plunger Seal - Virgin Teflon Uniseal w/Buna Insert	18-42-4B	N/A	18-82-4B
		Plunger Seal - Virgin Teflon Uniseal w/Viton Insert	18-42-4V	N/A	18-82-4V
		(Seals Continued Below)			

Sidewinder Pumps Inc. asserts Trademark rights in and to the distinctive appearance of Sidewinder Models 40/60/80 & 42/62/82 pumps and their various configurations.

SIDEWINDER PNEUMATIC PUMP MODEL NUMBER CHART

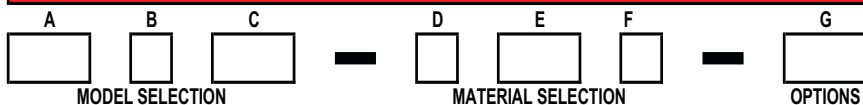

A PLUNGER 04 » 1/4" Dia. 06 » 3/8" Dia. 08 » 1/2" Dia. 16 » 1" Dia.

B PISTON 0 » 1-1/4" Dia. 2 » 2-1/4" Dia. 4 » 4" Dia.

C PRODUCTION SERIES*
 C » Models 44, 84, & 164
 CR » Models 44, 64, 84, & 164 *Controller Relay Versions*
 D » Models 42, 82, & 64
 E » Models 42, 62, 82 *Micrometer Stroke Adjust Versions*
 F » Model 62
 G » Models 40, 80
 H » Model 60

D PLUNGER MATERIAL
 0 » 17-4 SS (*Standard*) 5 » Hastelloy
 2 » 316 SS 6 » Titanium
 3 » 440C SS 7 » Chrome Plated SS
 4 » Ceramic 8 » Electroless Nickel Plated SS

E PLUNGER PACKING
 0 » Teflon Composite Uniseal (*Standard*)
 1 » Techno Uniseal - Polyimide
 2 » Viton O-Ring
 3 » Buna O-Ring
 4 » Teflon Uniseal
 4A » Teflon Uniseal w/Aflas O-Ring Insert
 4B » Teflon Uniseal w/Buna O-Ring Insert
 4V » Teflon Uniseal w/Viton O-Ring Insert
 5 » Chemraz O-Ring
 6 » Hitec O-Ring (*Aflas*)
 7 » Virgin Teflon O-Ring
 8 » Polyblend Uniseal
 8V » Polyblend Uniseal w / Viton Insert
 9 » Special (*Customer Specified*)
 EP » ERP O-Ring
 V » Viton EPT Z-lip / Teflon Carbon Uniseal

F CHECK VALVE AND PUMP CHAMBER MATERIAL
 2 » 316 SS (*Standard*)
 5 » Hastelloy
 6 » Titanium

G OPTIONS
 2 » Viton Piston U-Cup
 4 » Ceramic Check Valve Balls
 9 » Consult Factory
 GS » Gas Recovery
 MP » Ni Cobalt Moly Return Spring

* This field may be left blank. Sidewinder will automatically provide the latest series for the model you choose. Older models may be available on special request. You may place the older series letter here, if applicable.

18*#		(Seals Continued)			
	1	Plunger Seal - Chemraz O-Ring	18-42-5	18-62G-5	18-82-5
		Plunger Seal - Hitec O-Ring	18-42-6	18-62G-6	18-82-6
		Plunger Seal -Virgin Teflon O-Ring	18-42-7	N/A	N/A
		Plunger Seal - Polyblend Uniseal	18-42-8	18-62G-8	18-82-8
		Plunger Seal - Customer Specified	18-42-9	18-62G-9	18-82-9
		Plunger Seal - Teflon Graphite Uniseal w/ Viton Extreme Z-Lip Insert	18-42-V	18-62G-V	18-82-V
Note: O-ring Seals - Model 44C requires (1) O-ring and (2) narrow back up rings (18D-42), Model 64D requires (1) O-ring and (2) narrow back up rings (18D-62G), Model 84C requires (1) O-ring and (2) narrow back up rings (18D-82).					
20	1	Bleed Valve	20-42-2	20-42-2	20-42-2
22*	1	Suction Check Valve Assembly	22-42-2	22-82-2	22-82-2
23*	1	Discharge Check Valve Assembly	23-42-2	23-42-2	23-42-2
24	3	Pump Chamber	24-42-2	24-62-2	24-82-2
31	1	Timer Knob	31-42	31-42	31-42
33	1	Timer Stem	33-42C	33-42C	33-42C
35**	1	Timer Stem O-Ring	35-42	35-42	35-42
51	1	Control Valve Cover	51T-42C-2	51T-42C-2	51T-42C-2
52**	1	Control Valve Diaphragm	52-42	52-42	52-42
53	1	Control Valve Body	53-44-2	53-44-2	53-44-2
54**	1	Actuator	54-42	54-42	54-42
55**	1	Poppet	55-42	55-42	55-42
56**	1	Body Seal	56-42	56-42	56-42
57**	1	Spring	57-42	57-42	57-42
58**	2	Mounting Screw	58-42	58-42	58-42
91*#	1	Piston Grease	91-42	91-42	91-42
92*#	1	Plunger Lube (2 oz)	92-42	92-42	92-42
NOTES					
* Parts included in a pump end repair kit. Also included is 91-42 Silicon Piston Grease. This kit is designated by a "K" preceding the pump model number. The B and C Series in the Model 44/64/84 use the same Pump End Repair Kit.					
** Parts included in a timer valve repair kit. This part number is KVC-40F for the Model 44, Model 64, and the Model 84 pump. The series "C" Control Timer Valve does not require part #37-42 O-Ring Seal in the KVC-40 kit.					
# Parts included in Soft Parts Repair Kit. This kit is designated by a "K" preceding the pump model description and the seal identification number. Example: Soft Parts Kit for a model 42C-032 pump would be K42C-3.					
a Item 6 - Piston U-Cup in Viton - Part Number 6-44-2					
b Item 11 - Return Spring is available in Ni Cobalt Moly - Part Number 11-44-MP					
THEORETICAL FLUID VOLUME PUMPED					
Numbers are approximate. To insure accurate flow rates, Sidewinder recommends installation of a Pump Setting Gauge.					
1/4" Plungers: Quarts/Day = 1.5 x Strokes/Min					
3/8" Plungers: Quarts/Day = 3.0 x Strokes/Min					
1/2" Plungers: Quarts/Day = 6.0 x Strokes/Min					
At high pump rates, the volume per stroke will be slightly lower.					
Rule of Thumb					
1/4" Plunger, 1 spm = 1.5 Qt/Day; 3/8" Plunger, 1 spm = 3.0 Qt/Day; 1/2" Plunger, 1spm = 6 Qt/Day					

Sidewinder Pumps Inc. asserts Trademark rights in and to the distinctive appearance of Sidewinder Models 40/60/80 & 42/62/82 and their various configurations.



Suggested Pump Installation and System Set Up

There ain't no better pump

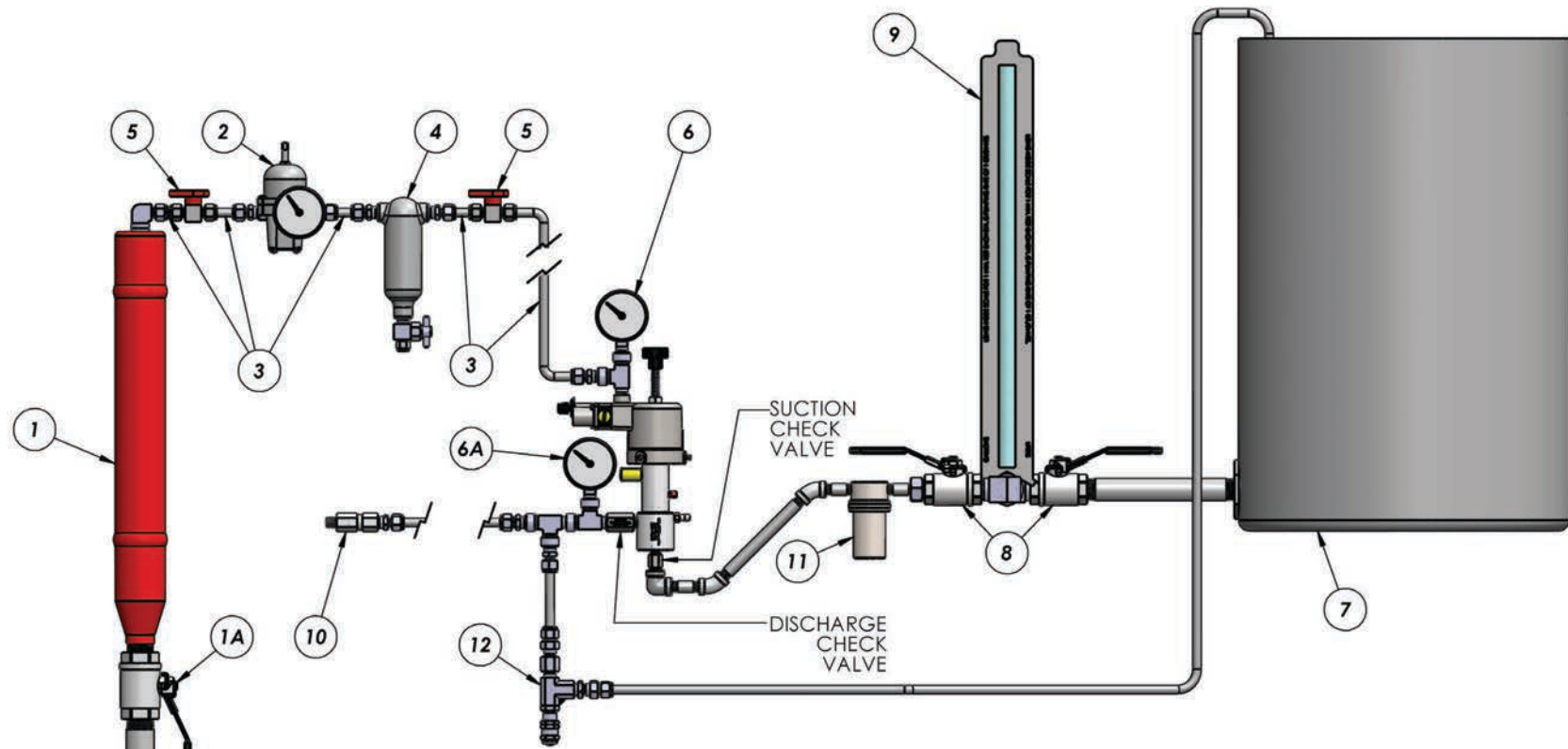

LEGEND

- | | |
|--|---|
| 1) SCRUBBER UNIT INSTALLED ON SUPPLY FLOW LINE | 6A) 1/4" TEE AT PUMP DISCHARGE WITH PRESSURE GAUGE |
| 1A) BALL VALVE - FLOW LINE | 7) CHEMICAL SUPPLY DRUM / TANK |
| 2) STEP DOWN REGULATOR WITH PRESSURE GAUGE | 8) BALL VALVES - ISOLATION VALVES FOR TANK |
| 3) SUPPLY LINE 3/8" TUBING | 9) PUMP SETTING GAUGE |
| 4) VOLUME BOTTLE / DROP OUT TANK WITH DRAIN | 10) IN-LINE DISCHARGE CHECK VALVE (AT POINT OF ENTRY) |
| 5) BALL VALVE | 11) IN-LINE SUCTION FILTER |
| 6) 1/4" TEE AT PUMP SUPPLY INLET WITH PRESSURE GAUGE | 12) RELIEF VALVE (SET AT 10% OVER M.O.P.) |

Troubleshooting The Sidewinder Chemical Pump

Problem	Possible Cause	Action
Control valve not cycling	<ul style="list-style-type: none"> No supply pressure Pump speed control closed Leak in control or valve Supply gas blowing through to exhaust due to speed control too wide, trash under valve seat or restriction in air/gas supply 	<ul style="list-style-type: none"> Check gauge on supply line at pump to verify adequate supply pressure... 10 to 150 psi. Rotate dial CCW three turns from full in position and then select desired rate. Rotate CW to slow pump rate Check for leak, pinched or missing seals, broken diaphragm, loose mounting screws, loose lock down nut on stroke adjuster. Rotate control dial CW to decrease setting. Block exhaust momentarily and then release. Verify supply line size minimum of 3/8" diameter, and a maximum distance from regulator to pump of 10 feet . Check for blockage in supply line and Timer Control. For pumps before serial #40755, contact the manufacturer.
Piston not stroking	<ul style="list-style-type: none"> Return spring broken Lack of grease/lube Plunger seal swollen Supply line pressure too low to buck process line pressure Stroke length adjuster screwed too far 	<ul style="list-style-type: none"> Replace spring (#11). Clean and lubricate power head and piston u-cup with Piston Grease #91-42. Clean plunger lube chamber and fill with Sidewinder Lube #92-42 on liquid lube models or with Sidewinder Grease #91-42 on grease lube models. Change piston and plunger seals if needed. Change to different seal material. Divide process line pressure by amplification ratio (see Performance Chart). Supply pressure must exceed this result. (Standard Sidewinder Control operates from 10 to 150 psi). Back out on stroke adjuster to desired setting.
No fluid discharge with timer control cycling and piston stroking	<ul style="list-style-type: none"> Air or vapor in pump chamber Fluid flow to pump blocked by plugged line, closed valve, extremely high viscosity or lack of fluid supply Suction or discharge check valve leaking Discharge line plugged Chemical filter clogged 	<ul style="list-style-type: none"> Open bleeder valve (#20), purge until steady flow of fluid, then close bleeder valve. If ambient temperature is close to vapor point of chemical, mount or situate pump on slight angle down from tank. Provide free flow of fluid to pump suction. Fluid level in tank must be above level of bleeder valve (#20). Put pump setting gauge in test position to determine which valve is leaking. Fluid falling then rising in gauge indicates suction check valve. Fluid level remaining constant indicates discharge check valve issue. Clear or replace line. Replace or clean filter element.
Premature seal failure	<ul style="list-style-type: none"> Chemical compatibility Abrasive material in chemical No seal lubricant or incorrect lube 	<ul style="list-style-type: none"> Check the plunger first. If plunger is scored, switch to more compatible material such as ceramic, and replace with same seal material. If seal fails, change to a different seal material. If plunger is okay, change seal material. Install suction filter. Use Sidewinder Lube #92-42 in liquid lube models, use Sidewinder Grease #91-42 in grease lube models.
Chemical leakage	<ul style="list-style-type: none"> Damaged or leaking suction line, discharge line or seal failure 	<ul style="list-style-type: none"> Close air/gas supply isolation ball valve (#5). Close isolation ball valve (#8) between pump setting gauge (#9) and chemical tank (#7). Close isolation ball valve (#8) between pump and pump setting gauge (#9). Close isolation ball valve between tee (#4H) and exhaust collection point.
Air/Gas supply leakage	<ul style="list-style-type: none"> Damaged or leaking Air/Gas Supply Line 	<ul style="list-style-type: none"> Close air/gas supply isolation ball valve (#5). Close isolation ball valve (#8) between pump setting gauge (#9) and chemical tank (#7). Close isolation ball valve (#8) between pump and pump setting gauge (#9). Close isolation ball valve between tee (#4H) and exhaust collection point.

NOTE: When performing repairs, follow the suggested procedures as described in Pump Repair or Emergency Shut Down section

NOTE: In the event of an emergency shut down, follow the suggested procedures as described in the Pump Repair or Emergency Shut Down section

NOTE: Item numbers referenced are in the Suggested Pump Installation and System Setup Diagram and Pump Breakdown

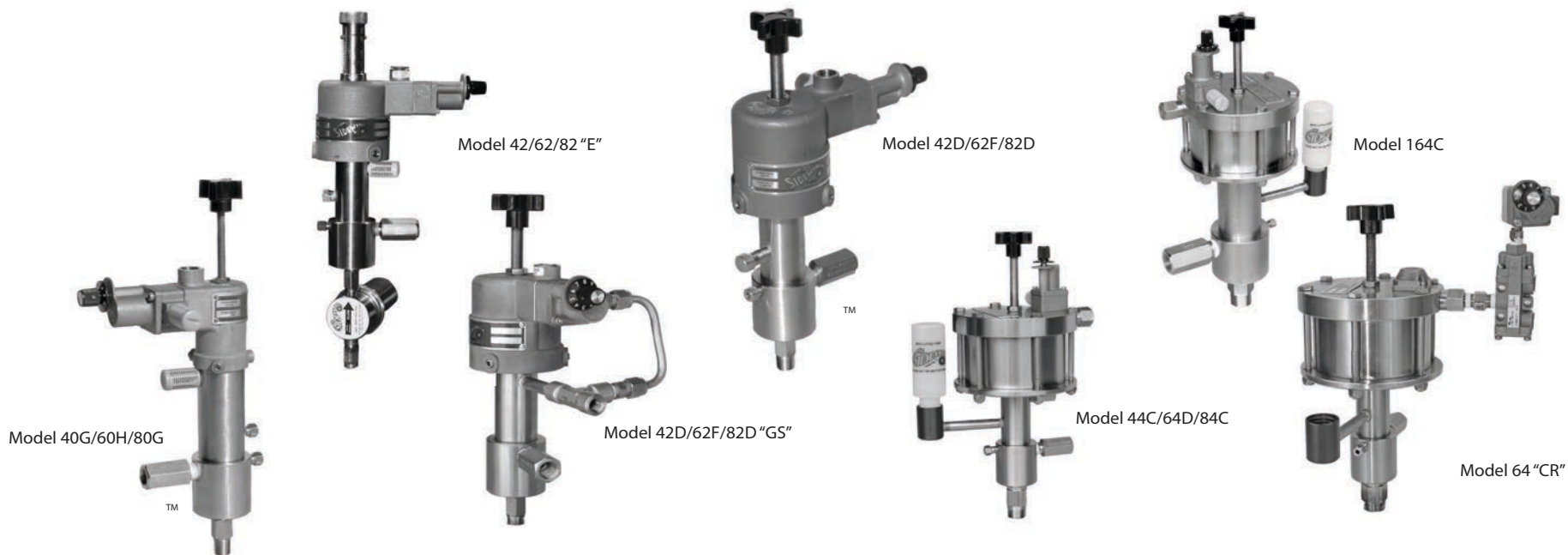

Pump Selection Guide & Performance Chart

Model Number	Plunger Size	Piston Size	Amplification Chart	Supply Pressure PSI	Discharge Pressure PSI(a)	Maximum Full Strokes Per Minute	Output Volume Qts./Day(b)
40	1/4"	1.25"	25:1	15 to 150	0 to 3,500	60	0 to 90
42	1/4"	2.25"	80:1	10 to 150	0 to 10,000	55	0 to 70
44	1/4"	4"	240:1	10 to 45	0 to 10,000	35	0 to 30
44CR	1/4"	4"	240:1	10 to 45	0 to 10,000	55	0 to 50
60	3/8"	1.25"	11:1	15 to 150	0 to 1,600	60	0 to 200
62	3/8"	2.25"	36:1	10 to 150	0 to 5,400	55	0 to 155
64	3/8"	4"	110:1	10 to 95	0 to 10,000	30	0 to 67
64CR	3/8"	4"	110:1	10 to 95	0 to 10,000	55	0 to 122
80	1/2"	1.25"	6.25:1	15 to 150	0 to 935	60	0 to 360
82	1/2"	2.25"	20:1	10 to 150	0 to 3,000	55	0 to 275
84	1/2"	4"	60:1	10 to 150	0 to 9,000	30	0 to 120
84CR	1/2"	4"	60:1	10 to 150	0 to 9,000	55	0 to 220
164	1"	4"	16:1	10 to 150	0 to 2,400	40	0 to 680
164CR	1"	4"	16:1	10 to 150	0 to 2,400	55	0 to 935

For information on Plunger Material & Plunger Packing Material, see Sidewinder Pump Model Number Chart inside of this brochure.

(a) 1 psig = 0.0703 kg/sq. cm • (b) 1 quart = 0.946 liters

www.sidewinderpumps.com

Sidewinder Pumps, Inc. asserts Trademark rights in and to the distinctive appearance of Sidewinder model 40/60/80 & 42/62/82 pumps.
Sidewinder Pumps, Inc. asserts Trademark rights in and to the distinctive appearance of Sidewinder's line of solar chemical pumps.