



P. O. Box 80769 • Lafayette, LA 70598-0769 • (337) 235-9838 • FAX (337) 235-9852 • www.sidewinderpumps.com

DC Powered, C1D2 - Chemical Injection Pump

Suggested Installation & Operating Instructions

BASIC SYSTEM SETUP:

Step 1: MOUNT THE PUMP - Securely fasten your Sidewinder Pump in the desired location. Sidewinder offers two versions of stands. The left-most stand below must be bolted in place. The right-most stand is free standing, but does have holes for staking or bolting in place.

- a) Using the (4) 1/4-20 Hex Head Screws supplied, mount the pump to the stand of your choice, shown below.
- b) As an alternate, the pump base can be bolted directly to your existing structure instead of to a stand.

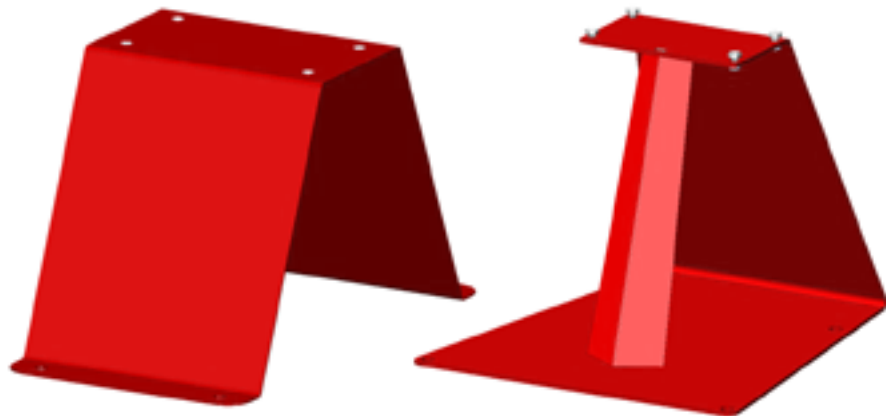

Step 2: PLUMBING THE PUMP: (See Illustration below – duplex version shown)

- a) Install pump setting gauge between two isolation ball valves as shown below.
- b) Install pump with suction filter and isolation ball valve between the pump and the pump setting gauge.
- c) Connect the feed line to the Suction Check Valve(s) using 1/4" MNPT connectors.
- d) Connect the discharge line to the Discharge Check Valve(s) using 1/4" MNPT connectors.
- e) 1/8" FNPT ports are provided for detection of seal leakage. They may be used to plumb drainage to containment area.
- f) **NOTE: Industry safety practice requires installation of a properly sized pressure safety valve at the discharge side of the pump.**
- g) **NOTE: Sidewinder Pumps Inc. strongly recommends the addition of a line check valve at the point of injection.**
- h) **NOTE: Do not use non-metallic discharge lines.**
- i) **NOTE: If using a "Divider Block" in the discharge line, a pressure safety valve must be installed in the discharge line at the pump. Failure to do so will void the pump warranty and most importantly, will create a safety hazard! (See Note "f" above also)**

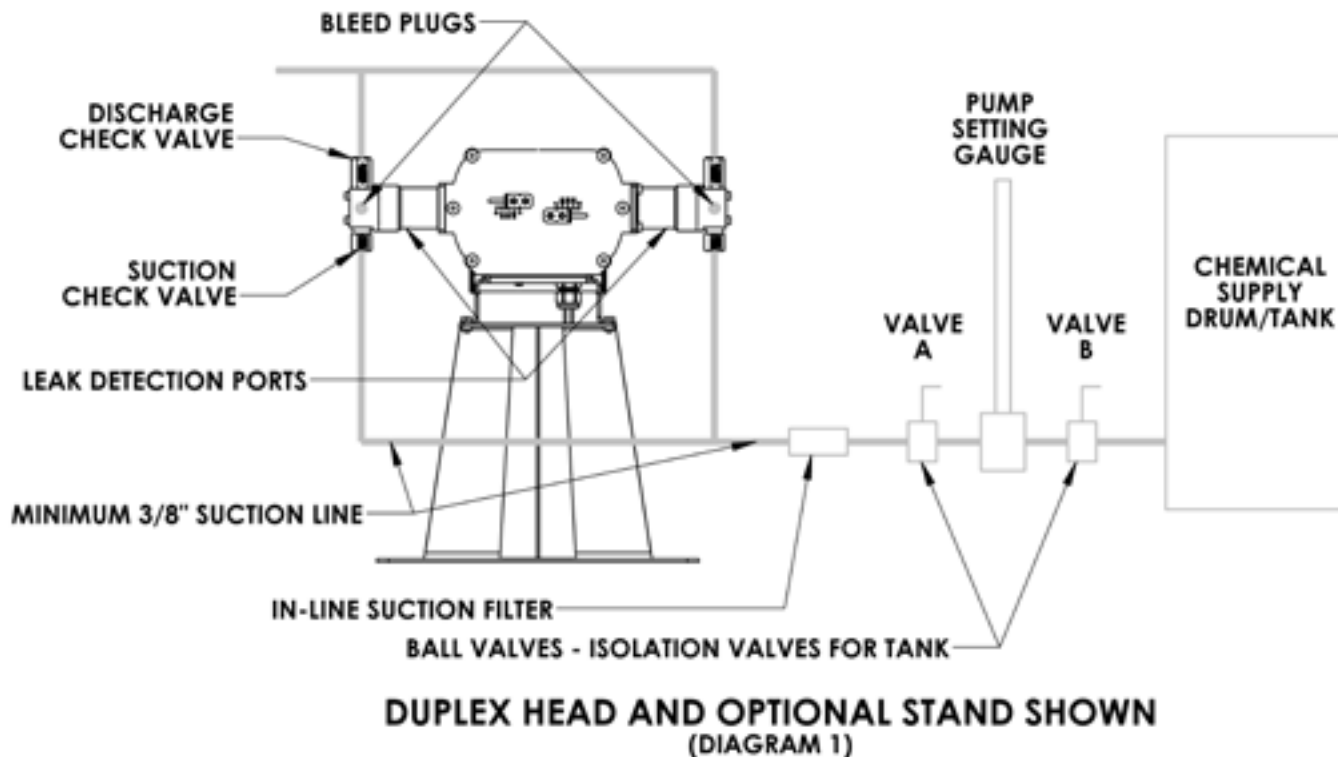

Step 3: ELECTRICAL REQUIREMENTS – Electric service wire or conduit is not supplied with your pump. For your pump to operate safely, it is required that an electrician certified to do work in Class 1 Division 2 areas make all power connections to the motor, in accordance with the standards set forth in the current NEC documentation.

- a) 12 VDC Power is to be supplied to your Sidewinder Pump via conduit designed for and approved for service in Class 1 Division 2 areas. Wires must be sized appropriately for the current (max 20A continuous) and for the distance the wire is being ran to the pump.
- b) Sidewinder strongly recommends the addition of a earth ground wire, minimum 14ga conductor be included in the wiring and connected to one of the green grounding screws inside the terminal box on the motor.

CAUTION! INSURE THAT ALL POWER IS "OFF" WHEN WIRING THE MOTOR!

- c) Remove the cover from the terminal box on the motor. Two leads, one red and one black are already connected to the appropriate points on the speed control board inside.
- d) Bring the appropriate wire (2b) into the terminal box via a 3/4" conduit fitting and conduit approved for use in an outdoor C1D2 environment. Terminate leads as shown, with appropriate wire nuts, or remove supplied leads and install using 1/4" quick connect female connectors.
- e) Re-install cover.



Step 4: FINAL CONNECTIONS and STARTUP: NOTE: The control on the side of the control box must be set to "0" first.

- a) Prime your pump prior to operation. Loosen the bleed plug(s) and either gravity feed, or run the pump at a slow pace (set speed to 30 to 40 on the control knob, temporarily) until the air is purged completely from the pump chamber and suction check valve.
- b) When pump is primed, tighten bleed plug(s), and set the speed control to the desired output rate. Verify output rate with pump setting gauge. (See Estimated Output Chart on sheet 9 of 10)



STEP 5: USING THE STROKE LIMITERS: Your pump is equipped with Sidewinder's stroke limiting system and you can make fine adjustments to pump output by setting stroke length.

- a) Sidewinder Pumps are shipped with the stroke limiter in its "Full Output" position.
- b) With the pump running, loosen (NEVER REMOVE! ONLY LOOSEN SLIGHTLY) the socket head cap screws, #6D, on the appropriate control tab #6B, while holding the tab in its full stroke position as indicated on the stamped graphics on the front of the pump. (F, 3/4, 1/2, 1/4, 0) are the markings on the coverplate.
- c) After loosening the two #6D stroke limiter screws on the appropriate stroke limiter control tab (again... do not remove!) you should be able to slide the control tab #6B outward, away from the "F" mark, to a lesser output setting. The tab may slide in and out as the internal plunger head comes against it, but with a little practice, you should be able to hold back against the plunger, and stop the plunger at the desired stroke length. Use the little notch in the control tab 6B as a reference point for setting the stroke limiter. When you have the control tab in the desired position, tighten the two stroke limiter screws #6D. Tighten the screws to a snug level. The control tab will remain at your set point. DO NOT OVERTIGHTEN as this could strip the internal threads and impair your ability to limit the pump's stroke length!
- d) If pump is installed, but not running... the ability to slide the control tab, #6B, outward against the system pressure may prove to be difficult or impossible. Shut fluid suction valve and open bleeder plug, #4H, to eliminate pump chamber pressure. The control tab, #6B, should move freely, only held back by the internal return spring, item #9. Set the stroke limiter to the desired setting, snug stroke limiter screws, #6D, holding stroke limiter in place. Close the bleeder plug, and open the suction supply valve. NOTE: The pump may need to be primed again, before service is continued.
- e) **NOTE: Setting a stroke limiter to "0" allows pump repairs/service to that side without shutting the pump off if necessary.**

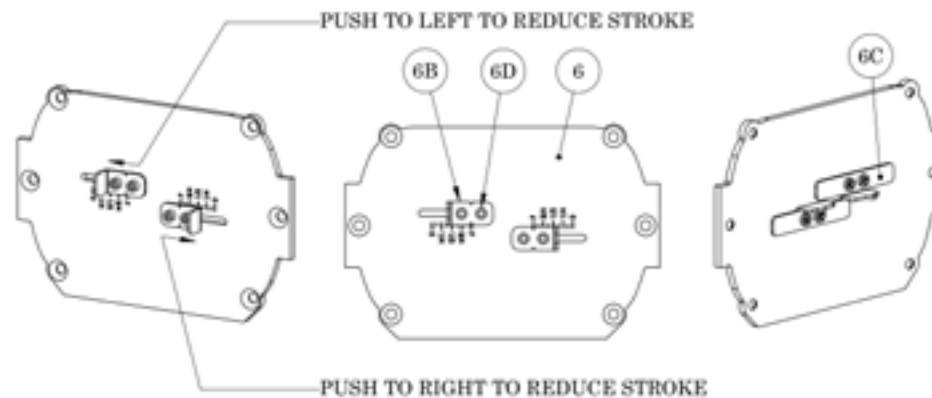

PARTS LIST: MAIN PUMP ASSEMBLY

Pump part number structure:

S	<input type="checkbox"/>	1-SIMPLEX; 2-DUPLEX	<input type="checkbox"/>	HAZARDOUS DUTY MOTOR	<input type="checkbox"/>	PLUNGER SIZE	<input type="checkbox"/>	PLUNGER SEAL	<input type="checkbox"/>	CHECK VALVE THREAD O-RING	<input type="checkbox"/>	CHECK VALVE BALL	<input type="checkbox"/>	WET END	<input type="checkbox"/>	PLUNGER OPTIONS	<input type="checkbox"/>	PLUNGER SIZE	<input type="checkbox"/>	PLUNGER SEAL	<input type="checkbox"/>	CHECK VALVE THREAD O-RING	<input type="checkbox"/>	CHECK VALVE BALL	<input type="checkbox"/>	WET END	<input type="checkbox"/>
LEFT SIDE														RIGHT SIDE													

SEE CHART AT END OF THIS DOCUMENT FOR OPTION CODES

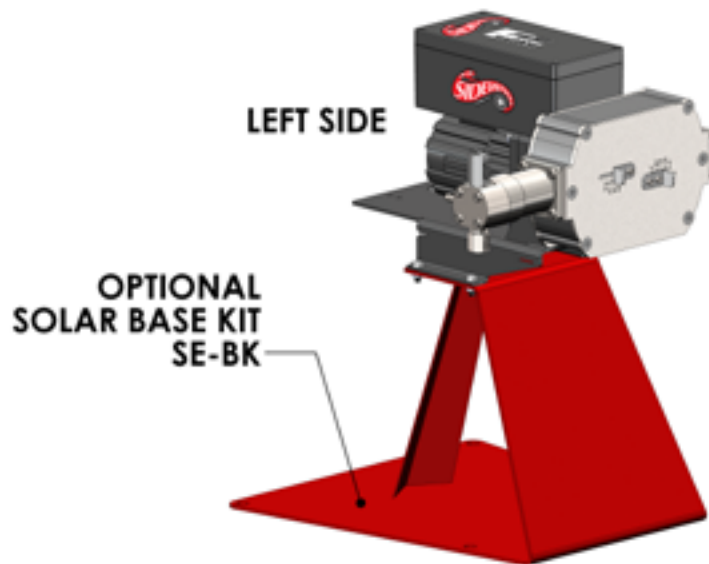
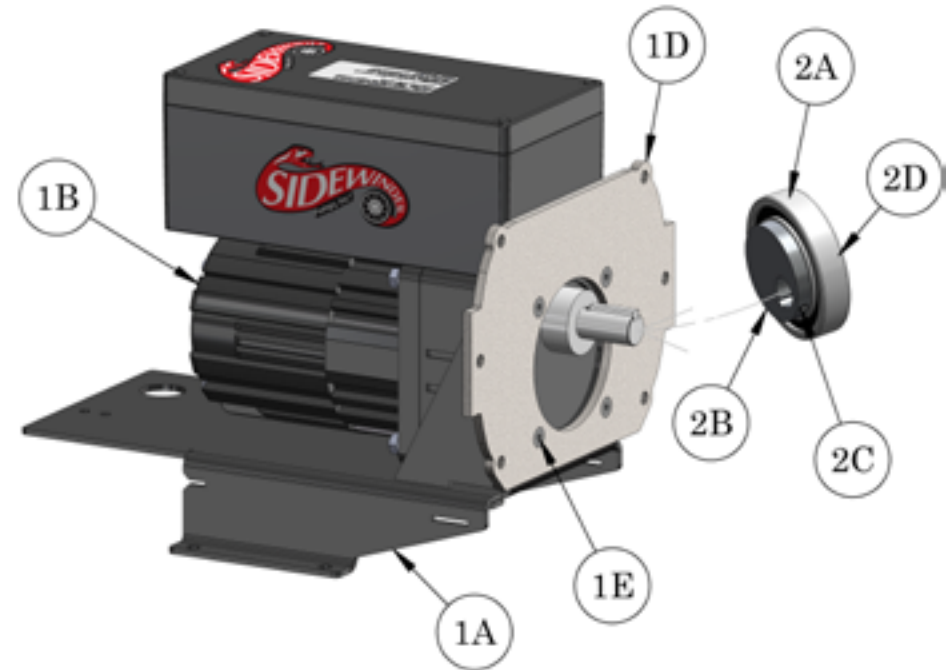

Item No.	Quantity	Part Description	Part Number
1	1	Motor & Base Assembly	SE-MBAHD-1-A
1A	1	Motor Base	SE-B-1-A
1B	1	Motor	SE-MAHD-1-A
1C	0	N/A	N/A
1D	1	Rear Coverplate	SE-P-1-H-1
1E	4	Screw, Motor Mount	C-002-12-1
2	1	Cam Assembly	SE-CA-8
2A	1	Bearing	SE-C-1-C
2B	1	Cam	SE-C-8-A
2C	1	Set Screw	C-004-06

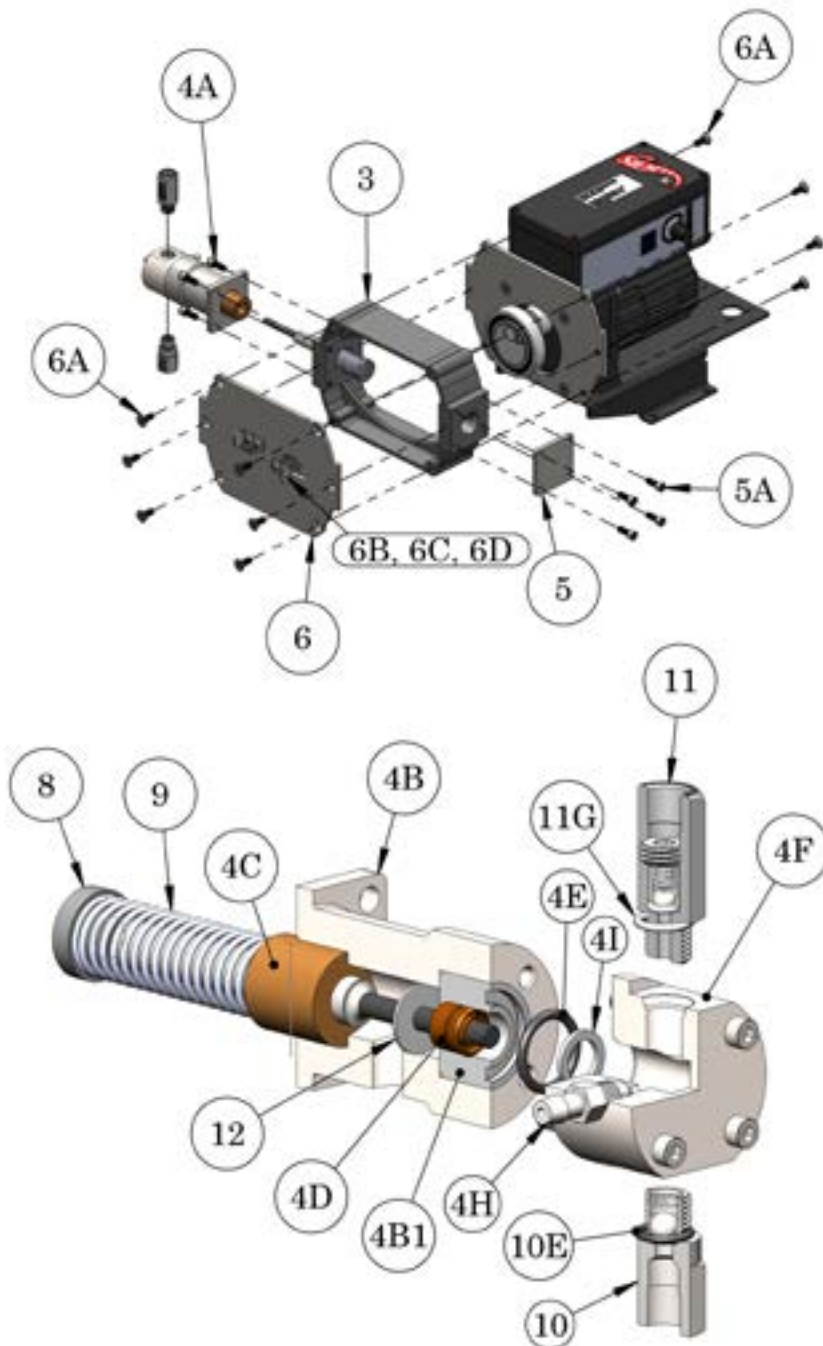

Item No.	Qty	Part Description	Part Number		
			1/4" Plunger	3/8" Plunger	1/2" Plunger
3	1	Pump Housing	AC-2-1		
3A	2	Screws, Timer Mount	C-012-10-3		
4 *	1	Pump Assembly	SE-PA-4062	SE-PA-6062	SE-PA-8062
4A	4	Screw, Mount Tube to Pump Housing	C-007-10-3		
4B	1	Mounting Tube	SE-MT-1-B		
4B1	1	Mounting Tube Insert	SE-MTI-4-A	SE-MTI-6-A	SE-MTI-8-A
4C	1	Bushing	SE-MT-1-D		
4D	1	Plunger Seal, Teflon Carbon Filled Graphite Uniseal (STANDARD) See Sheet 6 for optional seals	18-42	18-62G	18-82
4E	1	O-Ring, Pump Mounting Tube	C-006-115-6	C-006-118-6	C-006-118-6
4F	1	Pump Chamber	SE-PC-2-B		
4G	4	Pump Chamber Mounting Screw	C-005-28-1		
4H	1	Bleed Plug	SE-BP-1-A		
4I	1	Pump Chamber Shim	SE-SHIM-B	SE-SHIM-B	N/A
5 **	1	Simplex Coverplate	SE-SC-A		
5A	4	Screw, Simplex Coverplate	C-007-10-3		
6	1	Front Coverplate	SE-P-1-H-4		
6A	12	Screw, Coverplates to Housing	C-002-10-3		
6B	2	Stroke Limiter, Control Tab	SE-SL-1-A		
6C	2	Stroke Limiter, Stop	SE-SL-2-A		
6D	4	Screws, Stroke Limiter	C-021-08-3		
7	1	Motor Cover	SE-MC-A-W		
8 *	1	Plunger Assembly	SE-PLA-4-A	SE-PLA-6-A	SE-PLA-8-A
9 *	1	Return Spring	SE-RS-1-A		
10 *	1	Suction Check Valve	SE-CV-4-S-2-2-6		
10A	1	Suction Check Valve Body	SE-CV-4-S-2-A		
10B	1	Ball, Suction Check Valve	SE-CVB-6-2		
10C	1	O-Clip	22C-42-2		
10D	1	O-Ring, Suction Check Seat	C-006-010-7		
10E	1	O-Ring, Check Valve Thread	C-006-906-6		
11 *	1	Discharge Check Valve	SE-CV-4-D-2-2-6		
11A	1	Discharge Check Valve Body	SE-CV-4-D-2-A		
11B	1	Ball, Discharge Check Valve	22B-42-2		
11C	1	Valve Seat Sleeve	23D-42-2		
11D	1	Spring, Tapered	23C-42-2		
11E	1	Spring Retainer	23E-42-2		
11F	1	O-Ring, Discharge Check Seat	C-006-009-7		
11G	1	O-Ring, Check Valve to pump chamber	C-006-906-6		
12	1	Plunger Wiper	SW-PLW-250	SE-PLW-375	SE-PLW-500
*	Double quantities for duplex unit; Item 4 is shown in exploded view as Items 4A - 4I				
**	Simplex Unit Only				
***	1: O-Ring Seal for 1/4" plunger requires (1) O-Ring and (2) narrow backup rings (18D-42) 2: O-Ring Seal for 3/8" plunger requires (2) O-Rings & (3) narrow backup rings (18D-62)				

C1D2 Solar Pump Troubleshooting Guide

Problem	Possible Cause	Action
Pump Not Running	* Battery Low or Dead	<p>CAUTION! BEFORE ANY CHANGES, CONNECTIONS, TESTING... CERTIFY THAT AREA IS FREE OF ANY EXPLOSIVE FUMES, GASES, ETC! ANY CONNECTIONS OR CHANGES MUST BE PERFORMED BY AN ELECTRICIAN CERTIFIED TO WORK IN C1D2 HAZARDOUS AREAS!</p> <ul style="list-style-type: none"> * Check all electrical connections * Test battery and replace if necessary * Insure that solar panel is clean and getting full sunlight * Verify system design is adequate to meet autonomy requirements
	* Speed Set To Zero	* Set speed to point where acceptable volume output is registered on pump setting gauge.
	* Blown fuse	* Check fuse located in battery/control box. Check all connections. Verify that discharge line is not blocked or a valve closed, as this would lock up the pump and blow the fuse. SEE WARNING ABOVE!
	* Loose Connection in Wiring	* Have C1D2 Certified Electrician verify wiring is proper, with no loose connections. SEE WARNING ABOVE!
	* Motor failure	* Replace motor (if above actions do not correct issue) SEE WARNING ABOVE!
Pump Runs, No fluid discharge	* Air in pump chamber	* Open bleed plug (#4H) and purge until steady flow of fluid, then close bleed plug. If ambient temperature is close to vapor point of chemical, mount or situate pump on slight angle down from the tank. 1/4" plunger pumps may require removal of discharge check valve to completely bleed all air from the pump chamber.
	* Fluid flow blocked by plugged line, closed suction valve, extremely high viscosity or lack of fluid supply	* Provide free flow of fluid to pump suction, fluid level in tank must be above level of bleed plug
	* Suction or Discharge check valve leaking	* Put pump setting gauge in test position to determine which valve is leaking. Fluid falling then rising in the gauge indicates suction check valve, fluid level remaining constant in gauge indicates discharge check
	* Chemical filter clogged	* Replace filter element or clean filter
	* Return Spring broken	* Remove front coverplate (#6). Observe pump running. If plunger (#8) not fully engaging or following the cam, stop the pump and check for broken spring or sticking plunger. Replace spring (#9) or lubricate plunger.
	* Plunger Sticking	
* Stroke Limiter set to zero or very short stroke	* With Pump running, adjust stroke limiter (Loosen (2) #6D screws and adjust tab #6B, to allow a longer pump stroke. Always use	
Premature Seal Failure	* Chemical Compatibility	<ul style="list-style-type: none"> * Check the plunger first. If plunger is scored or damaged, replace plunger and seal. * If seal still fails, change to different seal material.
	* Abrasive Material in Chemical	* Install suction filter
	* Bushing (#4C) worn	* Replace bushing part # SE-MT-1-B.
Chemical leakage	* Damaged or leaking suction line, discharge line or seal failure	* Prior to repair:
		* Turn the speed control to the "ZERO (0)" or "OFF" position.
		* Close Isolation ball valve "B" between pump setting gauge and chemical tank (see Diagram 1 on page 2)
		* Close isolation ball valve "A" between pump and pump setting gauge (see Diagram 1 on page 2)

NOTE: Item numbers referenced in the troubleshooting guide are in the Pump Breakdown chart provided in this document.

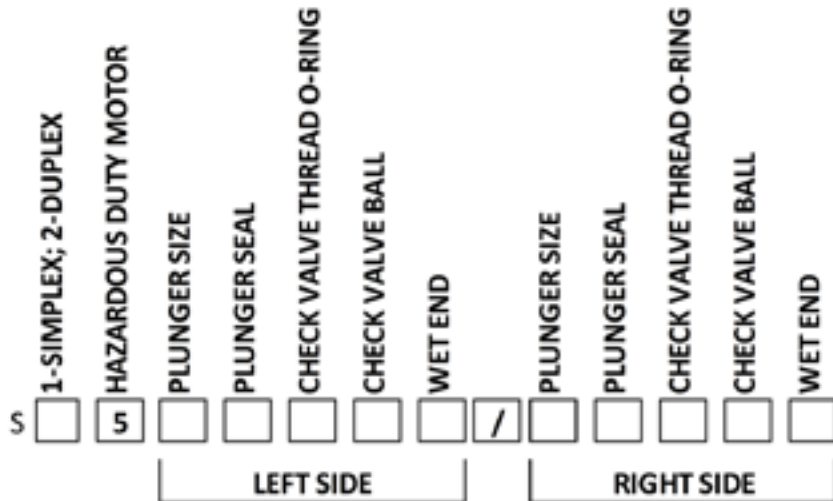

ITEM	CODE	DESCRIPTION	
PLUNGER SIZE	4	1/4"	
	6	3/8"	
	8	1/2"	
PLUNGER SEAL OPTIONS	0	TEFLON GRAPHITE UNISEAL	
	1	TECHNO UNISEAL (POLYIMIDE)	
	4	TEFLON UNISEAL	
	4A	TEFLON UNISEAL W/ AFLAS O-RING INSERT	
	4B	TEFLON UNISEAL W/ BUNA O-RING INSERT	
	4V	TEFLON UNISEAL W/ VITON O-RING INSERT	
	8	POLYBLEND UNISEAL	
	8V	POLYBLEND UNISEAL W / VITON INSERT	
	9	CUSTOMER SPECIFIED	
	V	VITON/CARBON TEFLON UNISEAL	
CHECK VALVE / BODY SEAL OPTIONS	2	VITON O-RING	
	3	BUNA O-RING	
	5	CHEMRAZ O-RING	
	6	HITEC O-RING (AFLAS)	
	7	VIRGIN TEFLON O-RING	
	CHECK VALVE BALL OPTIONS	2	316 STAINLESS STEEL
		4	CERAMIC
WET END	2	316 STAINLESS STEEL	
PLUNGER	4	CERAMIC COATED	

Manufacturer Disclaimer

Manufacturer recommends the use of 316 SS seamless tubing rated for the maximum discharge pressure of the specific pump model being used. DO NOT USE poly tubing, copper tubing, and/or seamed tubing as a discharge line. Use of incorrect material may result in discharge line failure leading to personal injury, death, and/or compromise to intended injection objectives. For Safety Purposes and Good Engineering Practice, the manufacturer recommends placement of a properly sized Pressure Relief Valve (PRV) / Pressure Safety Valve (PSV) on the pump discharge line at the pump, with the relief line plumbed back to the chemical tank.



There ain't no better pump

"Dedicated to providing state of the art metering solutions for all your chemical treatment needs."

Sidewinder Pumps Inc.
107 Commission Blvd., Lafayette, Louisiana 70508
P.O. Box 80769, Lafayette, LA 70598-0769

(337) 235-9838 / Fax (337) 235-9852 • www.sidewinderpumps.com • info@sidewinderpumps.com