



P. O. Box 80769 • Lafayette, LA 70598-0769 • (337) 235-9838 • FAX (337) 235-9852 • www.sidewinderpumps.com

C1D2 - AC Powered - Chemical Injection Pump

Suggested Installation & Operating Instructions

BASIC SYSTEM SETUP:

Step 1: MOUNT THE PUMP - Securely fasten your Sidewinder Pump in the desired location. Sidewinder offers two versions of stands shown below. The alternate stand must be bolted in place. The standard stand is free standing, but does have holes for staking or bolting in place. As an option, the pump base can be bolted directly to your existing structure instead of to a stand. (Middle picture is pump and controller which can be directly bolted to your structure.)



STANDARD BASE



ALTERNATE BASE

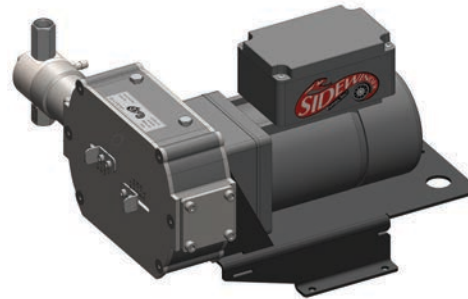

The pump, stand, and controller are supplied apart from each other. Follow these steps to connect them.

- Using (4) 1/4-20 Hex Head Screws (supplied with the stand), mount the AC Pump. There is no controller on the pump at this time.
- Using (2) 1/4-20 Hex Head Screws (supplied with the pump), mount Sidewinder's AC-TAC-1-A (C1D2 rated) controller to the top of the pump.

Step 2: PLUMBING THE PUMP: (See Illustration below – duplex version shown)

- a) Install pump setting gauge between two isolation ball valves as shown below.
- b) Install pump with suction filter and isolation ball valve between the pump and the pump setting gauge.
- c) Connect the feed line to the Suction Check Valve(s) using 1/4" MNPT connectors.
- d) Connect the discharge line to the Discharge Check Valve(s) using 1/4" MNPT connectors.
- e) 1/8" FNPT ports are provided for detection of seal leakage. They may be used to plumb drainage to containment area.
- f) **NOTE: Industry safety practice requires installation of a properly sized pressure safety valve at the discharge side of the pump.**
- g) **NOTE: Sidewinder Pumps Inc. strongly recommends the addition of a line check valve at the point of injection.**
- h) **NOTE: Do not use non-metallic discharge lines.**
- i) **NOTE: If using a "Divider Block" in the discharge line, a pressure safety valve must be installed in the discharge line at the pump.**
Failure to do so will void the pump warranty and most importantly, will create a safety hazard! (See Note " f " above also)

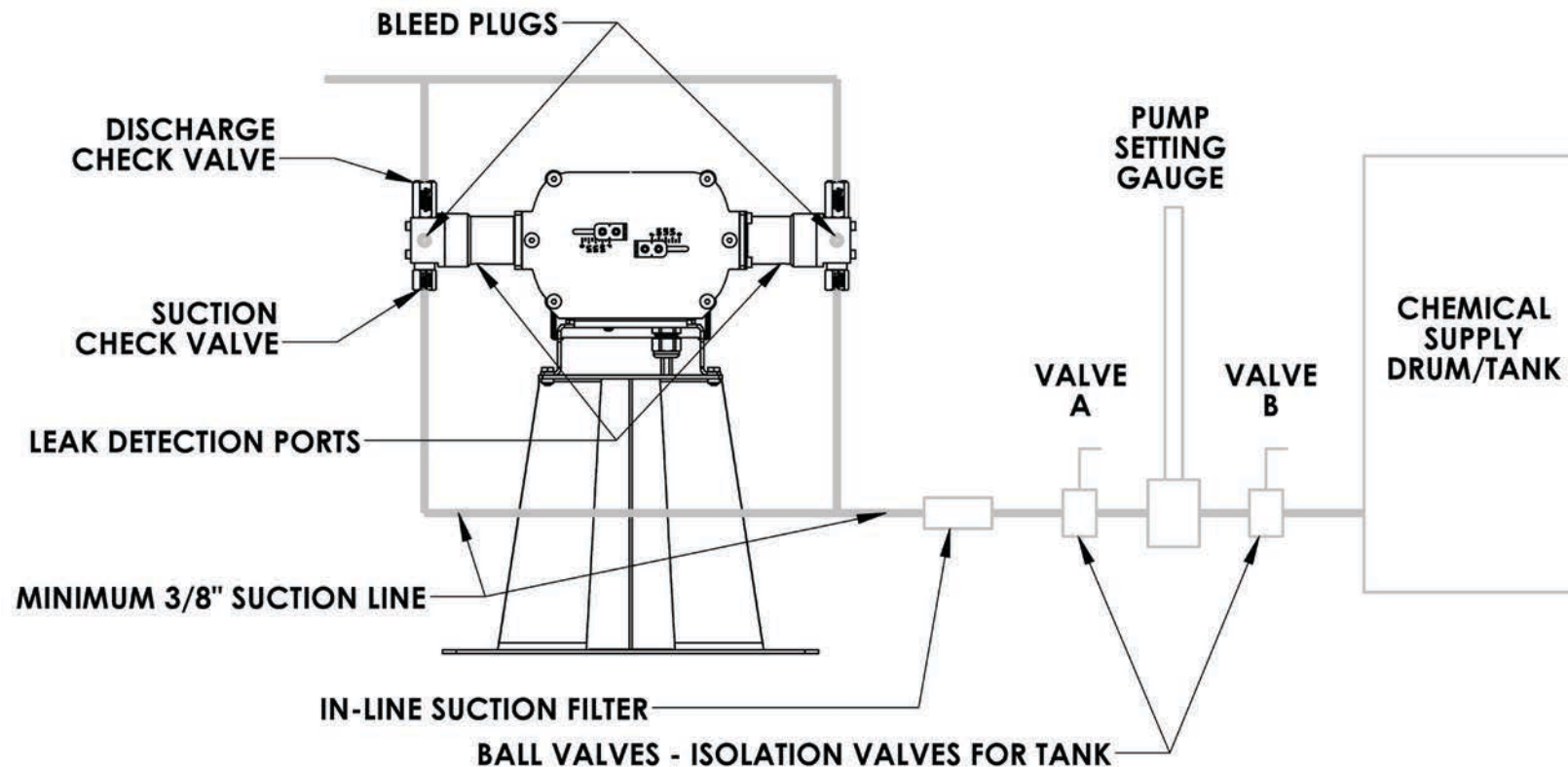

**DUPLEX HEAD AND OPTIONAL STAND SHOWN
(DIAGRAM 1)**

Step 3: Electrical Needs – Your Sidewinder Pump has a motor that is rated for use in C1D2 areas, and requires Sidewinder’s AC-TACHD-1-A timer (which is also C1D2 rated) for operation. ALL CONNECTIONS TO THE TIMER MUST BE PERFORMED BY AN ELECTRICIAN CERTIFIED FOR WORK IN C1D2 HAZARDOUS AREAS, AND ALL CONDUIT AND FITTINGS MUST BE APPROVED FOR C1D2 USE. 1/2” Trade Size fittings and conduit are required, and must have the proper agency approvals for use in C1D2 areas.

The AC-TACHD-1-A timer is clearly marked inside the lower cover area showing connection instructions. The wiring cover, and the control cover must be securely in place prior to normal production operation where a possibility of explosive gas or dust exists.

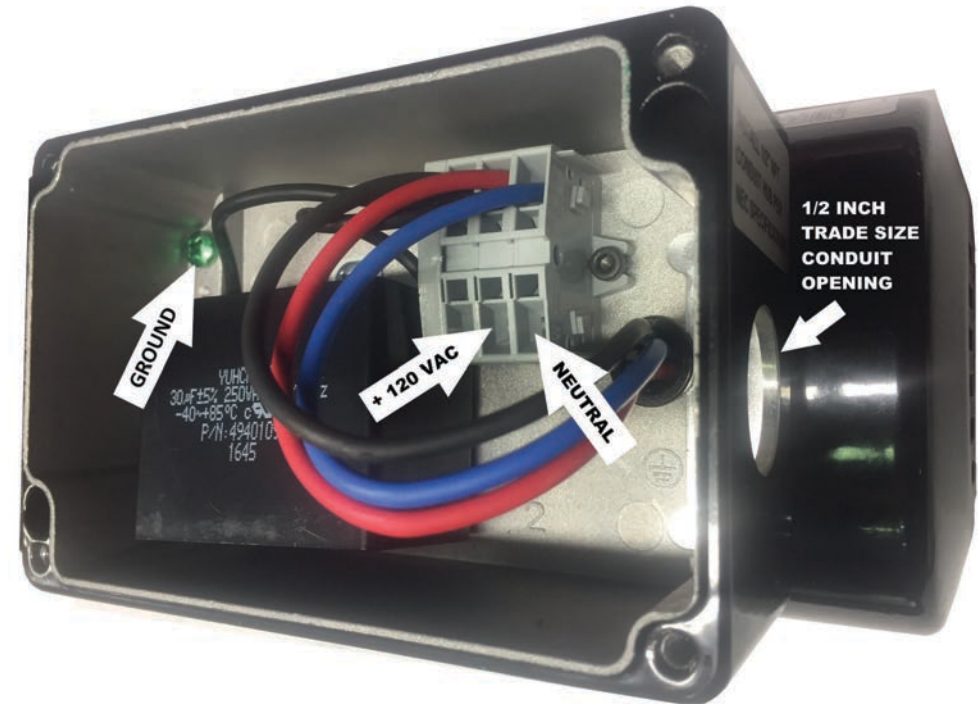
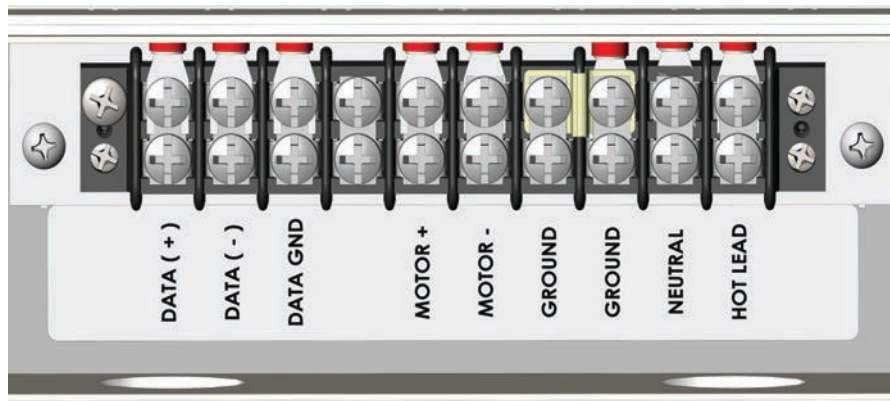

Step 4: FINAL CONNECTIONS and STARTUP: NOTE: Make sure the Timer Unit inside the control box is set to “OFF”.

- a) Prime your pump prior to operation. Loosen the bleed plug(s) and either gravity feed, or run the pump in its continuous mode until all air in the lines is purged. **See your Timer Manual (supplied) for timer instructions and features. See Section 5 of the timer manual for instructions on the “PRIME” function.**
- b) When pump is primed, tighten bleed plug(s), set pump to desired rate, and turn timer on. Verify flow rate with pump setting gauge.

PARTS LIST: MAIN PUMP ASSEMBLY

Pump part number structure:

	1-SIMPLEX; 2-DUPLEX	PLUNGER SIZE	PLUNGER SEAL	CHECK VALVE / BODY SEAL	CHECK VALVE BALL	WET END	PLUNGER OPTIONS
ACHD	<input type="checkbox"/>	<input type="checkbox"/>	<input type="checkbox"/>	<input type="checkbox"/>	<input type="checkbox"/>	<input type="checkbox"/>	<input type="checkbox"/>

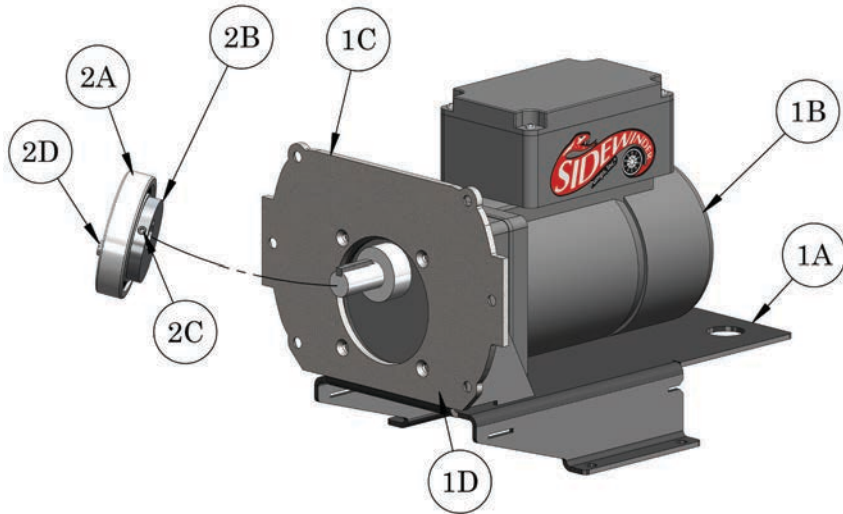

AC TIMER/CONTROLLER
PART NUMBER: AC-TACHD-1-A

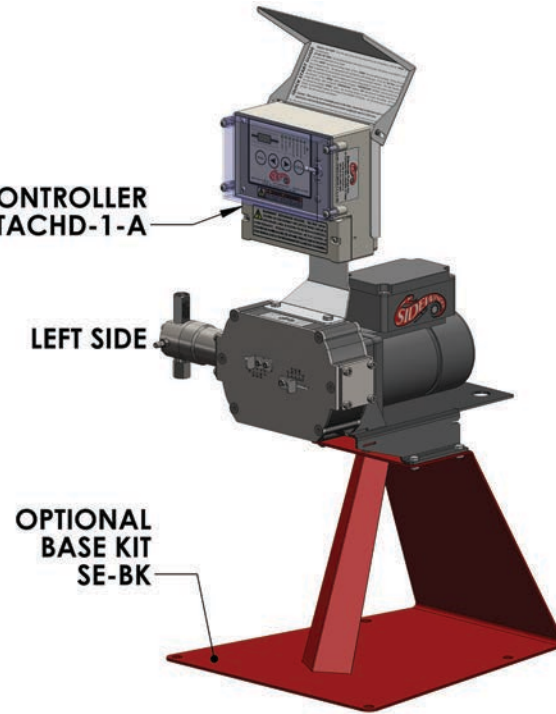

Item No.	Qty.	Part Description	Part Number
1	1	Motor & Base Assembly	AC-MBAHD-1-A
1A	1	Motor Base	SE-B-1-A
1B	1	Motor	AC-MAHD-1-A
1C	1	Rear Coverplate	SE-P-1-H-2
1D	4	Screws, Motor Mount	C-002-12-1
2	1	Cam Assembly	SE-CA-10
2A	1	Bearing	SE-C-1-C
2B	1	Cam	SE-C-10-A
2C	1	Set Screw	C-004-06
2D	1	Cam/Bearing Lockscrew	C-015-06-2

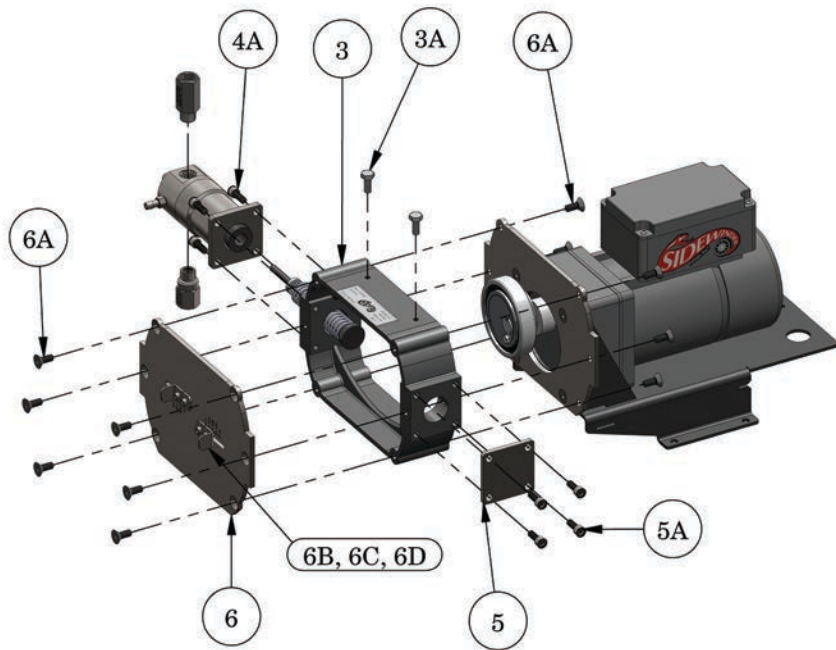

SEE NOTE 1

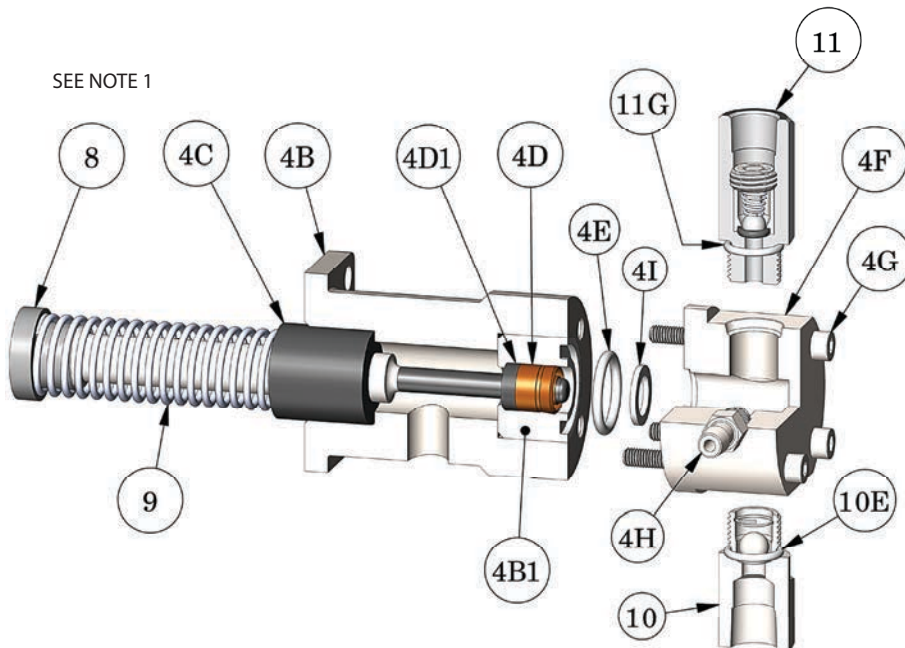

Item No.	Qty	Part Description	Part Number		
			1/4" Plunger	3/8" Plunger	1/2" Plunger
3	1	Pump Housing	AC-2-1		
3A	2	Screws, Timer Mount	C-012-10-3		
4 *	1	Pump Assembly	SE-PA-4062	SE-PA-6062	SE-PA-8062
4A	4	Screw, Mount Tube to Pump Housing	C-007-10-3		
4B	1	Mounting Tube	SE-MT-1-B		
4B1	1	Mounting Tube Insert	SE-MTI-4-A	SE-MTI-6-A	SE-MTI-8-A
4C	1	Bushing	SE-MT-1-D		
4D	1	Plunger Seal, Teflon Carbon Filled Graphite Uniseal (STANDARD) See Page 8 for optional seals	18-42	18-62G	18-82
4D1	1	Backup Ring	18D-42	18D-62G	18D-82
4E	1	O-Ring, Pump Mounting Tube	C-006-116-6	C-006-119-6	C-006-119-6
4F	1	Pump Chamber	SE-PC-2-B		
4G	4	Pump Chamber Mounting Screw	C-005-28-3		
4H	1	Bleed Plug	SE-BP-1-A		
4I	1	Pump Chamber Shim	SE-SHIM-B	SE-SHIM-B	N/A
5 **	1	Simplex Coverplate	SE-SC-A		
5A	4	Screw, Simplex Coverplate	C-007-10-3		
6	1	Front Coverplate	SE-P-1-H-4		
6A	12	Screw, Coverplates to Housing	C-002-10-3		
6B	2	Stroke Limiter, Control Tab	SE-SL-1-A		
6C	2	Stroke Limiter, Stop	SE-SL-2-A		
6D	4	Screws, Stroke Limitier	C-021-08-3		
7	-	Motor Cover	N / A		
8 *	1	Plunger Assembly	SE-PLA-4-A	SE-PLA-6-A	SE-PLA-8-A
9 *	1	Return Spring	SE-RS-1-A		
10 *	1	Suction Check Valve	SE-CV-4-S-2-2-6		
10A	1	Suction Check Valve Body	SE-CV-4-S-2-A		
10B	1	Ball, Suction Check Valve	SE-CVB-5-2		
10C	1	G-Clip	22C-42-2		
10E	1	O-Ring, Check Valve to pump chamber	C-006-010-7		
11 *	1	Discharge Check Valve	SE-CV-4-D-2-2-6		
11A	1	Discharge Check Valve Body	SE-CV-4-D-2-A		
11B	1	Ball, Discharge Check Valve	22B-42-2		
11C	1	Valve Seat Sleeve	23D-42-2		
11D	1	Spring, Tapered	23C-42-2		
11E	1	Spring Retainer	23E-42-2		
11F	1	O-Ring, Discharge Check Seat	C-006-009-7		
11G	1	O-Ring, Check Valve to pump chamber	C-006-906-6		
*	Double quantities for duplex unit; Item 4 is shown in exploded view as Items 4A - 4I				
**	Simplex Unit Only				
NOTE 1	To change the plunger size, replace Items Items: 4B1, 4D, 4D1, 4E, 8, AND 12 ONLY. ATTENTION: Item 4I is not used with 1/2" plunger assemblies.				

USING THE STROKE LIMITERS:

Your pump is equipped with Sidewinder's stroke limiting system and you can make fine adjustments to pump output by setting the stroke length.

- a) Sidewinder Pumps are shipped with the stroke limiter in its "Full Output" position.
- b) With the pump running, loosen (NEVER REMOVE! ONLY LOOSEN SLIGHTLY) the socket head cap screws, #6D, on the appropriate control tab #6B, while holding the tab in its full stroke position as indicated on the stamped graphics on the front of the pump. (F, 3/4, 1/2, 1/4, 0) are the markings on the coverplate.
- c) After loosening the two #6D stroke limiter screws on the appropriate stroke limiter control tab (again... do not remove!) you should be able to slide the control tab #6B outward, away from the "F" mark, to a lesser output setting. The tab may slide in and out as the internal plunger head comes against it, but with a little practice, you should be able to hold back against the plunger, and stop the plunger at the desired stroke length. Use the little notch in the control tab 6B as a reference point for setting the stroke limiter. When you have the control tab in the desired position, tighten the two stroke limiter screws #6D. Tighten the screws to a snug level. The control tab will remain at your set point. **DO NOT OVERTIGHTEN** as this could strip the internal threads and impair your ability to limit the pump's stroke length!
- d) If pump is installed, but not running... the ability to slide the control tab, #6B, outward against the system pressure may prove to be difficult or impossible. Shut the fluid suction valve and open the bleeder plug, #4H, to eliminate pump chamber pressure. The control tab, #6B, should move freely, only held back by the internal return spring, item #9. Set the stroke limiter to the desired setting, snug stroke limiter screws, #6D, holding stroke limiter in place. Close the bleeder plug, and open the suction supply valve.
NOTE: The pump may need to be primed again, before service is continued.
- e) Note: Setting a stroke limiter to "0" allows pump repairs/service to that side without shutting the pump off if necessary.

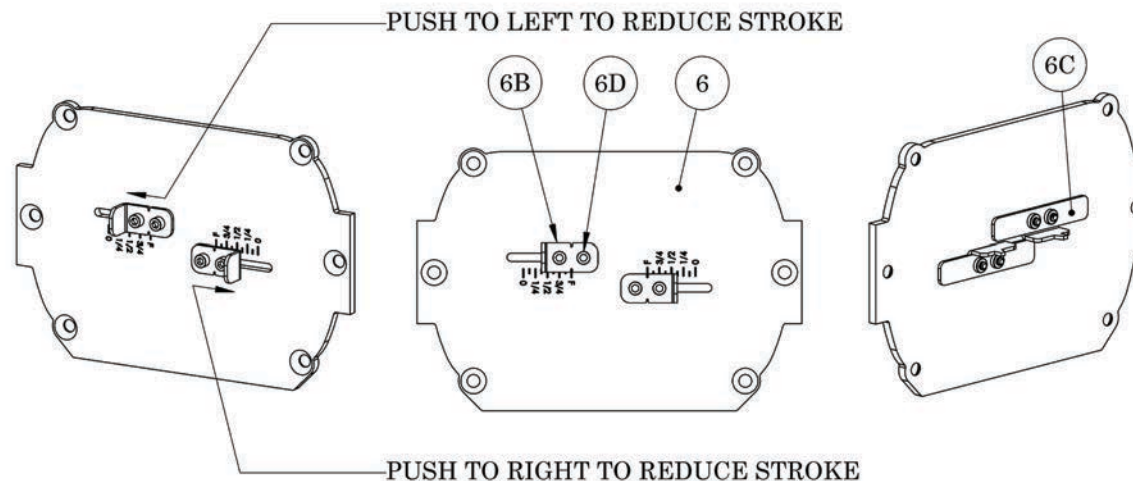

Troubleshooting - Sidewinder CID2 AC Chemical Injection Pump

Problem	Possible Cause	Action
Pump not running	• AC Power out or unit unplugged	• Check all electrical connections. • Verify that AC incoming power is within 114 to 126 VAC.
	• Timer turned off	• Reset the timer breaker located on the top of the timer.
	• Tripped circuit breaker switch on timer/controller	• Check switch on timer/controller. Check all connections. Verify that discharge line is not blocked or a valve closed.
	• Motor failure	• Replace motor (if above actions do not correct issue).
Pump runs, no fluid discharge	• Air in pump chamber	• Open bleed plug (#4H) and purge until steady flow of fluid, then close bleed plug. If pump continues vapor locking remove spring from the discharge check valve to purge vapor. 1/4" plunger pumps may require removal of discharge check valve to completely bleed all air from the pump chamber.
	• Fluid flow blocked by plugged line, closed suction valve, extremely high viscosity or lack of fluid supply	• Provide free flow of fluid to pump suction, fluid level in tank must be above level of bleed plug.
	• Suction or Discharge check valve leaking	• Use pump setting gauge in test position to determine which valve is leaking. Fluid falling then rising in the gauge indicates suction check valve, fluid level remaining constant in gauge indicates discharge check.
	• Chemical filter clogged	• Replace filter element or clean filter.
	• Return spring broken	• Remove front coverplate (#6). Observe pump running. If plunger (#8) not fully engaging or following the cam, stop the pump and check for broken spring or sticking plunger. Replace spring (#9) or lubricate plunger.
	• Plunger sticking	
	• Stroke limiter set to zero or very short stroke	• With Pump running, adjust stroke limiter (Loosen (2) #6D screws and adjust using tab #6B), to allow a longer pump stroke. Always use a full stroke if possible. Reduce output by adjusting timer settings, then use stroke limiter for fine tuning pump output.
Premature seal failure	• Chemical compatibility	• Check the plunger first. If plunger is scored or damaged, replace plunger and seal. • If seal still fails, change to different seal material.
	• Abrasive material in chemical	• Install suction filter.
	• Bushing (#4C) worn	• Replace bushing part # SE-MT-1-B.
Chemical leakage	• Damaged or leaking suction line, discharge line or seal failure	• Prior to repair: • Open the timer box and turn the timer to the "OFF" position.
		• Close Isolation ball valve "B" between pump setting gauge and chemical tank (see Diagram 1 on page 3).
		• Close isolation ball valve "A" between pump and pump setting gauge (see Diagram 1 on page 3).

NOTE: Item numbers referenced in the troubleshooting guide are in the Pump Breakdown chart provided in this document.

Manufacturer Disclaimer

Manufacturer recommends the use of 316SS seamless tubing rated for the maximum discharge pressure of the specific pump model being used. DO NOT USE poly tubing, copper tubing, and/or seamed tubing as a discharge line. Use of incorrect material may result in discharge line failure leading to personal injury, death, and /or compromise to intended injection objectives. For Safety Purposes and Good Engineering Practice, the manufacturer recommends placement of a properly size Pressure Relief Valve (PRV) / Pressure Safety Valve (PSV) on the pump discharge line at the pump, with the relief line plumbed back to the chemical tank.

PARTS LIST: MAIN PUMP ASSEMBLY

Pump part number structure:

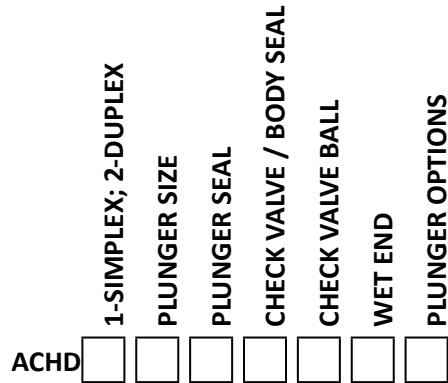

ITEM	CODE	DESCRIPTION
PLUNGER SIZE	4	1/4"
	6	3/8"
	8	1/2"
PLUNGER SEAL OPTIONS	0	TEFLON GRAPHITE UNISEAL
	1	TECHNO UNISEAL (POLYIMIDE)
	4	TEFLON UNISEAL
	4A	TEFLON UNISEAL W/ AFLAS O-RING INSERT
	4B	TEFLON UNISEAL W/ BUNA O-RING INSERT
	4V	TEFLON UNISEAL W/ VITON O-RING INSERT
	8	POLYBLEND UNISEAL
	8V	POLYBLEND UNISEAL W / VITON INSERT
	9	CUSTOMER SPECIFIED
	V	VITON EPT Z-LIP/CARBON TEFLON UNISEAL
CHECK VALVE / BODY SEAL OPTIONS	2	VITON O-RING
	3	BUNA O-RING
	5	CHEMRAZ O-RING
	6	HITEC O-RING (AFLAS)
	7	VIRGIN TEFLON O-RING
CHECK VALVE BALL OPTIONS	2	316 STAINLESS STEEL
	4	CERAMIC
WET END	2	316 STAINLESS STEEL
PLUNGER OPTIONS		LEAVE BLANK FOR STD. CERAMIC COATED
	0	17-4 STAINLESS STEEL

Manufacturer Disclaimer

When installing pump, manufacturer recommends the use of 316SS seamless tubing rated for the maximum discharge pressure of the specific pump model being used. DO NOT USE poly tubing, copper tubing, and/or seamed tubing as a discharge line. Use of incorrect material may result in discharge line failure leading to personal injury, death, and/or compromise to intended injection objectives. For Safety Purposes and Good Engineering Practice, the manufacturer recommends placement of a properly sized Pressure Relief Valve (PRV) / Pressure Safety Valve (PSV) on the pump discharge line at the pump, with the relief line plumbed back to the chemical tank.

APPROXIMATE QUARTS PER DAY AT VARIOUS ON-TIME / OFF-TIME SETTINGS

(ALWAYS VERIFY ACTUAL OUTPUT WITH A PUMP CALIBRATION GAUGE)

BATCH DOSING SETTINGS	PLUNGER DIAMETER	ON MIN	OFF MIN	SIMPLEX QTS / DAY	DUPLEX QTS / DAY	PLUNGER DIAMETER	ON MIN	OFF MIN	SIMPLEX QTS / DAY	DUPLEX QTS / DAY	PLUNGER DIAMETER	ON MIN	OFF MIN	SIMPLEX QTS / DAY	DUPLEX QTS / DAY
	1/4"	60	0	73.5	146.9	3/8"	60	0	165.3	330.6	1/2"	60	0	293.9	587.8
	1/4"	55	5	67.3	134.7	3/8"	55	5	151.5	303.1	1/2"	55	5	269.4	538.8
	1/4"	50	10	61.2	122.4	3/8"	50	10	137.8	275.5	1/2"	50	10	244.9	489.8
	1/4"	45	15	55.1	110.2	3/8"	45	15	124.0	248.0	1/2"	45	15	220.4	440.8
	1/4"	40	20	49.0	98.0	3/8"	40	20	110.2	220.4	1/2"	40	20	195.9	391.8
	1/4"	35	25	42.9	85.7	3/8"	35	25	96.4	192.9	1/2"	35	25	171.4	342.9
	1/4"	30	30	36.7	73.5	3/8"	30	30	82.7	165.3	1/2"	30	30	146.9	293.9
	1/4"	25	35	30.6	61.2	3/8"	25	35	68.9	137.8	1/2"	25	35	122.4	244.9
	1/4"	20	40	24.5	49.0	3/8"	20	40	55.1	110.2	1/2"	20	40	98.0	195.9
	1/4"	15	45	18.4	36.7	3/8"	15	45	41.3	82.7	1/2"	15	45	73.5	146.9
	1/4"	10	50	12.2	24.5	3/8"	10	50	27.6	55.1	1/2"	10	50	49.0	98.0
	1/4"	5	55	6.1	12.2	3/8"	5	55	13.8	27.6	1/2"	5	55	24.5	49.0
1/4"	1	59	1.2	2.4	3/8"	1	59	2.8	5.5	1/2"	1	59	4.9	9.8	

INTERMITTENT FLOW SETTINGS	PLUNGER DIAMETER	ON SEC	OFF SEC	SIMPLEX QTS / DAY	DUPLEX QTS / DAY	PLUNGER DIAMETER	ON SEC	OFF SEC	SIMPLEX QTS / DAY	DUPLEX QTS / DAY	PLUNGER DIAMETER	ON SEC	OFF SEC	SIMPLEX QTS / DAY	DUPLEX QTS / DAY
	1/4"	60	0	73.5	146.9	3/8"	60	0	165.3	330.6	1/2"	60	0	293.9	587.8
	1/4"	55	5	67.3	134.7	3/8"	55	5	151.5	303.1	1/2"	55	5	269.4	538.8
	1/4"	15	3	61.2	122.4	3/8"	15	3	137.8	275.5	1/2"	15	3	244.9	489.8
	1/4"	12	4	55.1	110.2	3/8"	12	4	124.0	248.0	1/2"	12	4	220.4	440.8
	1/4"	6	3	49.0	98.0	3/8"	6	3	110.2	220.4	1/2"	6	3	195.9	391.8
	1/4"	7	5	42.9	85.7	3/8"	7	5	96.4	192.9	1/2"	7	5	171.4	342.9
	1/4"	8	8	36.7	73.5	3/8"	8	8	82.7	165.3	1/2"	8	8	146.9	293.9
	1/4"	7	10	30.3	60.5	3/8"	7	10	68.1	136.1	1/2"	7	10	121.0	242.0
	1/4"	6	12	24.5	49.0	3/8"	6	12	55.1	110.2	1/2"	6	12	98.0	195.9
	1/4"	4	12	18.4	36.7	3/8"	4	12	41.3	82.7	1/2"	4	12	73.5	146.9
	1/4"	2	10	12.2	24.5	3/8"	2	10	27.6	55.1	1/2"	2	10	49.0	98.0
	1/4"	2	22	6.1	12.2	3/8"	2	22	13.8	27.6	1/2"	2	22	24.5	49.0
1/4"	1	59	1.2	2.4	3/8"	1	59	2.8	5.5	1/2"	1	59	4.9	9.8	

MAXIMUM PRESSURES: 1/4" - 5000 PSI, 3/8" - 2500 PSI, 1/2" 1250 PSI

Pump Output Table Notes:

- 1) Output rates less than 1.2 Quarts / Day may be achieved by setting "ON TIME" to seconds, and "OFF TIME" to minutes. Contact the factory for more information.
- 2) Pump outputs in shaded areas may require more frequent replacement of seals.



There ain't no better pump

"Dedicated to providing state of the art metering solutions for all your chemical treatment needs."

Sidewinder Pumps Inc.
107 Commission Blvd., Lafayette, Louisiana 70508
P.O. Box 80769, Lafayette, LA 70598-0769

(337) 235-9838 / Fax (337) 235-9852 • www.sidewinderpumps.com • info@sidewinderpumps.com