



Models
40/60/80
"D" Series

P.O. Box 80769 • Lafayette, LA 70598-0769 • (337) 235-9838 • FAX (337) 235-9852 • www.sidewinderpumps.com

Pneumatic Powered - Plunger Pumps

Installation • Operation • Performance • Power Requirements • Parts List
Model Code • Trouble Shooting

Installation & Operation Instructions

- 1) Install Model C-779-AG-S Drum Gauge into small bung of chemical drum and place test lever in lock position. This should block flow from drum to drum gauge.
- 2) Install Sidewinder Chemical Injector Pump in a vertical position on drum gauge. Use 1/2" x 1/4" NPT bushing on 1/4" pumps. (Optional) Install the (2) two 13A-42 Vents into the 1/8" NPT openings on item 12 Mounting Tube and item 53 Control Valve Body.
- 3) Connect discharge line to 1/4" NPT discharge check valve. For safety, a 1/4" line check valve (LC-4S) is recommended for installation where discharge line connects to process line.
- 4) Connect power gas or air line to supply inlet. The Sidewinder Controller accepts 15 to 150 psi.
- 5) Unscrew Trico Oiler Bulb and fill with Plunger Lube (#92-42) which is supplied. Quickly replace bulb and screw on tight. Plunger lube level will equalize.
- 6) Unlock test lever on drum gauge, open bleeder valve (#20) to remove air from pump chamber, and then close bleeder.

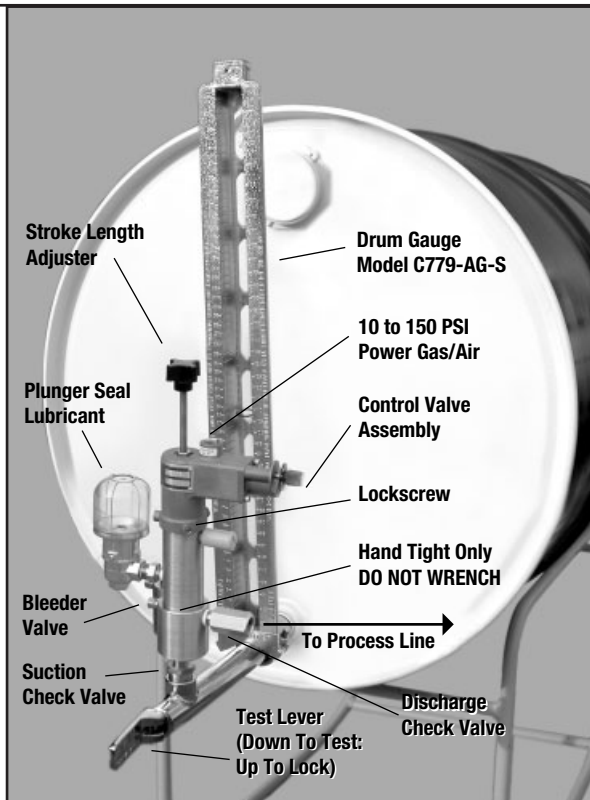

- 7) Set supply regulator to provide sufficient supply of gas or air to firmly stroke pump against prevailing discharge pressure. (Note: If supply volume is restricted due to either too small or too long of a supply line, pump control valve will blow through).
- 8) Depress test lever on drum gauge so suction is taken directly from sight glass with pump stroking. Note change in gauge glass level for one full minute. Raised marks on each side of glass represent quarts per day and liters per day when timed for one minute.
- 9) Adjust speed of pump by rotating dial (#31) on side of pump head. Clockwise rotation decreases the number of strokes per minute. Further volume control can be accomplished by varying the length of stroke with the stroke length adjusting screw (#1) on top of power head.
- 10) With test lever released, pump will take suction directly from drum. Gauge level will indicate volume of chemical remaining in drum.

Parts List / Model 40, 60, 80 - 'D' Series

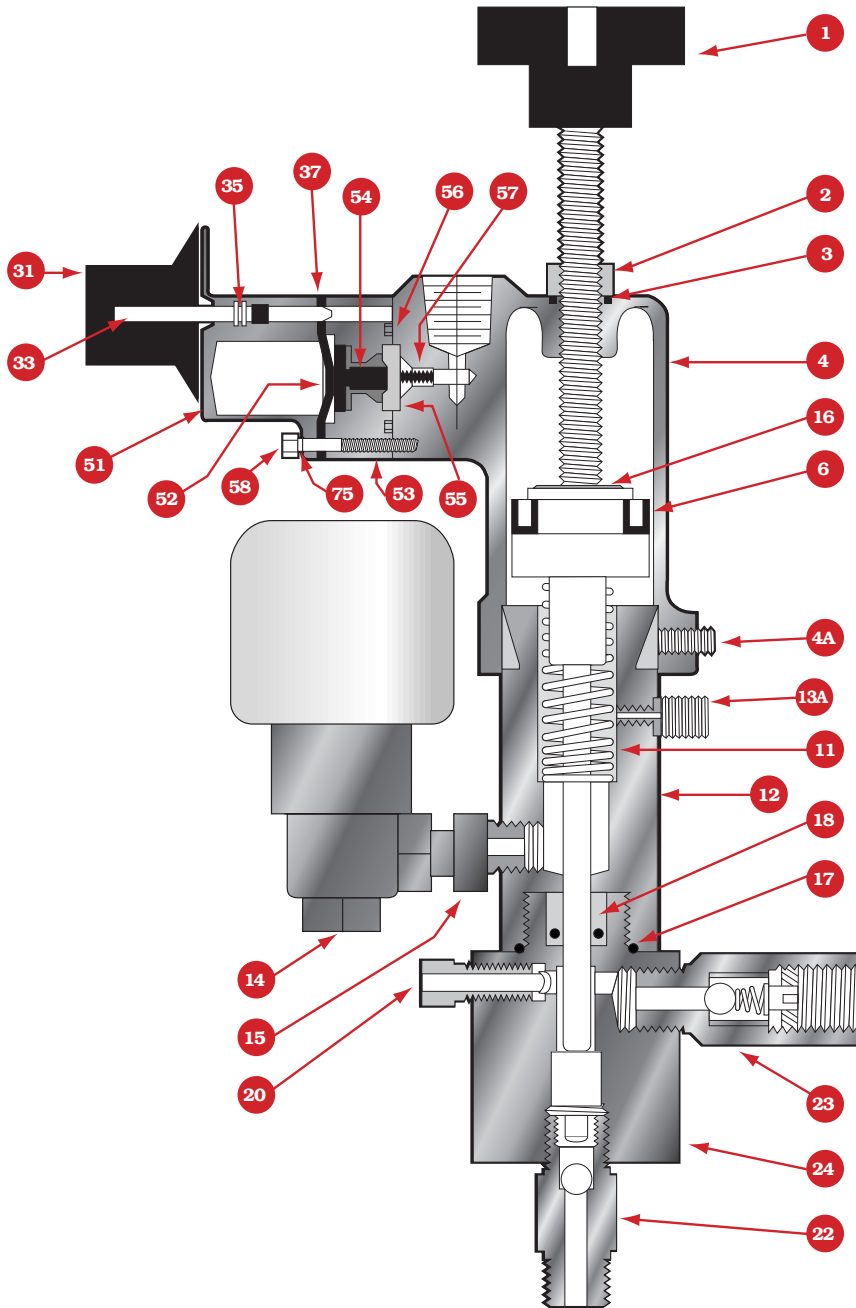

Item No.	Quantity Required	Part Description	Part Number		
			Model 40	Model 60	Model 80
1	1	Stroke Adjuster	1-40-C	1-40-C	1-40-C
2	1	Locknut-Stroke Adjuster	2-40	2-40	2-40
3*	1	Seal-Stroke Adjuster	3-40	3-40	3-40
4	1	Powerhead	4-40-2	4-40-2	4-40-2
4A	3	Lockscrews	4A-42-B	4A-42-B	4A-42-B
6* ^a	1	U-Cup (Viton available-see notes)	6-40	6-40	6-40
11* ^b	1	Return Spring (Spring options see notes)	11-42	11-42	11-42
12	1	Mounting Tube	12C-40	12C-60	12C-80
13A	2	Vent	13A-42	13A-42	13A-42
14	1	Lubricator	14-430	14-430	14-430
15	1	Lube Tube	15-40	15-40	15-40
16*	1	Piston-Plunger (17-4 SS)	16-40	16-60	16-80
		Piston-Plunger (316 SS)	16-40-2	16-60-2	16-80-2
		Piston-Plunger (440C SS)	16-40-3	16-60-3	16-80-3
		Piston-Plunger (Ceramic)	16-40-4	16-60-4	16-80-4
		Piston-Plunger (Hastelloy)	16-40-5	16-60-5	16-80-5
		Piston-Plunger (Titanium)	16-40-6	16-60-6	16-80-6
		Piston-Plunger (Stainless Steel w/ Chrome Plating)	16-40-7	16-60-7	16-80-7
		Piston-Plunger (Stainless Steel w/ Electroless Nickel Plating)	16-40-8	16-60-8	16-80-8
		Customer Specified Special	16-40-9	16-60-9	16-80-9
17*	1	O-Ring Mounting Tube	17-42	17-42	17-42
18*	1	Plunger Seal (Teflon Carbon Filled Graphite Uniseal)	18-42	18-62	18-82
		Plunger Seal (Techno Uniseal)	18-42-1	18-62-1	18-82-1
		Plunger Seal (Viton O-Ring)	18-42-2	18-62-2	18-82-2
		Plunger Seal (Buna O-Ring)	18-42-3	18-62-3	18-82-3
		Plunger Seal (Virgin Teflon Uniseal)	18-42-4	18-62-4	18-82-4
		Plunger Seal (Virgin Teflon Uniseal w/Buna Insert)	18-42-4B	N/A	18-82-4B
		Plunger Seal (Virgin Teflon Uniseal w/Viton Insert)	18-42-4V	N/A	18-82-4V
		Plunger Seal (Chemraz O-Ring)	18-42-5	18-62-5	18-82-5
		Plunger Seal (Hitec O-Ring)	18-42-6	18-62-6	18-82-6
		Plunger Seal (Virgin Teflon O-Ring)	18-42-7	N/A	18-82-7
		Plunger Seal (Polyblend Uniseal)	18-42-8	18-62-8	18-82-8
		Customer Specified Special	18-42-9	18-62-9	18-82-9

(Seals Continued Below)

Sidewinder Pump Model Number Chart

Fill in boxes below to determine
Sidewinder Pump Size & Material Requirements

Pump Size

Materials Required



Plunger Size

- 04 0.250"
- 06 0.375"
- 08 0.500"
- 16 1.000"

Piston Size

- 0 1.25"
- 2 2.25"
- 4 4.00"

Plunger Material

- 0 17-4 SS (Standard)
- 2 316 SS
- 3 440C SS
- 4 Ceramic
- 5 Hastelloy
- 6 Titanium
- 7 Stainless Steel
w/ Chrome Plating
- 8 Stainless Steel w/
Electroless Nickel Plating
- 9 Special

Check Valve & Body Material

- 316 SS (Standard) 2
- Hastelloy 5
- Titanium 6

Plunger Packing

- Teflon Graphite 0
- Uniseal
- Techno Uniseal 1
- Viton O-Ring 2
- Buna O-Ring 3
- Teflon Uniseal 4
- Teflon Uniseal 4B
w/ Buna O-Ring
Insert
- Teflon Uniseal 4V
w/ Viton O-Ring
Insert
- Chemraz O-Ring 5
- Hitec O-Ring 6
- Teflon O-Ring 7
- Polyblend Uniseal 8
- Special 9

(Seals Continued)

18*	NOTE: O-Ring Seals – Model 40 requires (1) O-ring and (2) narrow back up rings (18D-42), Model 60 requires (2) O-rings and (3) narrow back up rings (18D-62), Model 80 requires (1) O-ring & (2) narrow back up rings (18D-82).				
20	1	Bleeder Valve	20-42-2	20-42-2	20-42-2
22*	1	Suction Check Valve	22-42-2	22-82-2	22-82-2
23*	1	Discharge Check Valve	23-42-2	23-42-2	23-42-2
24	1	Pump Chamber	24-42-2	24-62-2	24-82-2
31	1	Control Knob	31-42	31-42	31-42
33	1	Valve Stem	33-42	33-42	33-42
35**	1	O-Ring Stem	35-42	35-42	35-42
37**	1	O-Ring Seat	37-42	37-42	37-42
51	1	Control Valve Cover w/ Timer	51T-42-2	51T-42-2	51T-42-2
52**	1	Diaphragm	52-42	52-42	52-42
53	1	Control Valve Body	53-42-2	53-42-2	53-42-2
54**	1	Actuator	54-42	54-42	54-42
55**	1	Poppet	55-42	55-42	55-42
56**	1	Body Seal	56-42	56-42	56-42
57**	1	Spring	57-42	57-42	57-42
58**	2	Mounting Screw	58-42	58-42	58-42
75**	2	Mounting Screw Lockwasher	75-42	75-42	75-42
92*	1	Plunger Seal Lubricant	92-42	92-42	92-42

Notes

* Parts included in a pump end repair kit. Also included is a 91-42 Silicone Piston Grease. This kit is designated by a "K" preceding the pump model number.

** Parts included in a timer valve repair kit. This part number is KVC-40 for the Model 40, Model 60, and the Model 80 pump.

NOTE: First generation Model 40 & Model 80 Sidewinder Pumps are denoted by serial numbers before 5821. These models require a 9-40 Spiral Ring and only one 4A-40 Lockscrew.

^a Item 6 Piston U-Cup in Viton – Part # 6-42-4

^b Item 11 Return Spring available in Ni Cobalt Moly – part number #11-42-MP.

Theoretical Fluid Volume Pumped

Numbers are approximate; to insure accurate flow rates Sidewinder Pumps recommends installing a Pump Setting Gauge.

Quarts/Day = 1.5 x Strokes/Min. for 1/4" Plunger

Quarts/Day = 3.0 x Strokes/Min. for 3/8" Plunger

Quarts/Day = 6.0 x Strokes/Min. for 1/2" Plunger

At high pump rates, volume per stroke is reduced slightly.

Rule of Thumb:

For 1/4" Plunger, 1 spm = 1.5 Qt/Day • For 3/8" Plunger, 1 spm = 3.0 Qt/Day • For 1/2" Plunger, 1 spm = 6 Qt/Day

Trouble Shooting The Sidewinder Chemical Pump

Problem	Possible Cause	Action
Control Valve Not Cycling	<ul style="list-style-type: none"> No supply pressure Pump speed control closed Leak in control or valve Supply gas blowing through to exhaust due to speed control too wide, trash under valve seat or restriction in air/gas supply line. 	<ul style="list-style-type: none"> Check gauge on supply line near pump to verify adequate supply pressure . . . 15 to 150 psi. Check for trash or dirt in pump air/gas inlet. Rotate dial CCW three turns from full in position and then set desired rate. Rotate CW to slow pump rate. Check for leak, pinched or missing seals, broken diaphragm or loose mounting screws. Rotate control dial CW to decrease setting. Block exhaust momentarily and then release. DO NOT USE BARE FINGERS. If this does not work, replace Timer Seat O-Ring #37-42 or increase supply line size and move pump closer to air/gas supply source.
Piston Not Stroking	<ul style="list-style-type: none"> Return spring broken Piston stuck due to lack of piston or plunger lube Piston stuck due to seal swelling Supply line pressure too low to buck process line pressure Stroke length adjuster screwed too far 	<ul style="list-style-type: none"> Replace spring. Clean and lubricate power head and piston with Piston Lube #91-42. Clean plunger lube chamber and fill with Plunger Lube #92-42. Change piston and plunger seals if needed. Change to different seal Divide process line pressure by amplification ratio (see Performance Chart). Supply pressure must exceed this result. (Standard Sidewinder Control operates from 10 to 150 psi.) Back out on stroke adjuster to desired setting.
No Fluid Discharge With Control Valve Cycling and Piston Stroking	<ul style="list-style-type: none"> Air or vapor in pump chamber Fluid flow to pump blocked by plugged line, closed valve, extremely high viscosity or lack of fluid supply. Suction or discharge check-valve leaking Discharge line plugged 	<ul style="list-style-type: none"> Open bleeder valve, fill chamber with fluid only, then close bleeder valve. Provide free flow of fluid to pump suction. Use drum gauge with handle in test position to determine which valve is leaking. Clean or replace faulty valve. Clear or replace line.
Premature Seal Failure	<ul style="list-style-type: none"> Chemical incompatibility between seal and material being pumped Scored or damaged plunger Abrasive material in chemical No lubricant or incorrect lube 	<ul style="list-style-type: none"> Check Compatibility Chart and install seal made from compatible material. Replace plunger. Install suction filter. Use Sidewinder Lube #91-42 on piston and #92-42 on plunger. Periodically check lube level.

Pump Selection Guide & Performance Chart

Model Number	Plunger Size	Piston Size	Amplification Chart	Supply Pressure PSI	Discharge Pressure PSI(a)	Maximum Full Strokes Per Minute	Output Volume Qts./Day(b)
40	1/4"	1.25"	25:1	15 to 150	0 to 3,750	60	0 to 90
42	1/4"	2.25"	80:1	10 to 150	0 to 10,000	55	0 to 70
44	1/4"	4"	240:1	10 to 45	0 to 10,000	35	0 to 30
60	3/8"	1.25"	11:1	15 to 150	0 to 1,600	60	0 to 200
62	3/8"	2.25"	36:1	10 to 150	0 to 5,400	55	0 to 155
64	3/8"	4"	110:1	10 to 150	0 to 10,000	30	0 to 67
80	1/2"	1.25"	6.25:1	15 to 150	0 to 935	60	0 to 360
82	1/2"	2.25"	20:1	10 to 150	0 to 3,000	55	0 to 275
84	1/2"	4"	60:1	10 to 150	0 to 9,000	30	0 to 120
164	1"	4"	16:1	10 to 150	0 to 2,400	40	0 to 680

For information on Plunger Material & Plunger Packing Material, see Sidewinder Pump Model Number Chart inside of this brochure.

(a) 1 psig = 0.0703 kg/sq. cm • (b) 1 quart = 0.946 liters

www.sidewinderpumps.com