



P.O. BOX 80769 • 107 Commission Blvd • LAFAYETTE, LOUISIANA 70598-0769
(337) 235-9838 • FAX # (337) 235-9852 • www.sidewinderpumps.com

Pneumatic Powered — Plunger Pumps

Installation • Operation • Performance • Power Requirements
Parts Lists • Model Code • Trouble Shooting

Installation & Operating Instructions for Sidewinder Model 164 'C' Chemical Metering Pump

- 1) Install Sidewinder Chemical Injector Pump in a vertical position with $\frac{3}{4}$ " NPT suction Check Valve #22-164-2 facing down.
- 2) Connect discharge line to $\frac{1}{2}$ " NPT discharge check valve. For safety, a $\frac{1}{4}$ " NPT line check valve (LC-4S) is recommended for installation where discharge line connects to process line.
- 3) Connect power gas or air line to $\frac{1}{4}$ " NPT supply inlet. The Sidewinder Controller accepts 10 to 150 psi.
- 4) Turn lube body #14-42 180 degrees. Screw bottle of lube oil #92-122 onto lube body. Rotate bottle and body so that bottle is upside down (do not squeeze or puncture bottle).
- 5) Open bleeder plug #20-42-2 to remove air from pump chamber, and then close bleeder.
- 6) Set supply regulator to provide sufficient supply pressure of gas or air to firmly stroke pump against prevailing discharge pressure. (Note: If supply volume is restricted due to either too small or too long of a supply line, pump control valve will blow through or act erratic.)
- 7) Adjust speed of pump by rotating Time Knob #31-42 on top of Power Head Cap #4A-44-2. Clockwise rotation decreases the number of strokes per minute. Counter-clockwise rotation increases the number of strokes per minute. Further volume control can be accomplished by varying the length of stroke with the Stroke Adjuster #1-42 also on top of the Power Head Cap.
- 8) In order to gauge volumes, consult your Sidewinder Pump Distributor for the proper gauging equipment.

SIDEWINDER MODEL 164 'C' SERIES PUMP

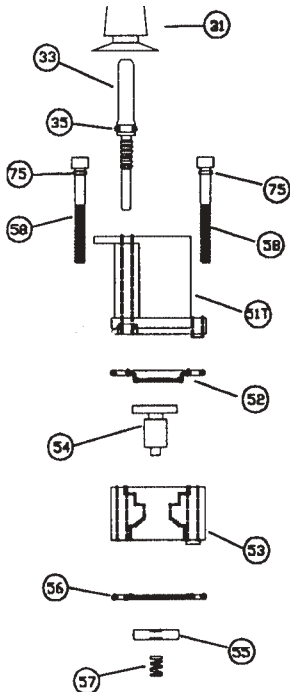
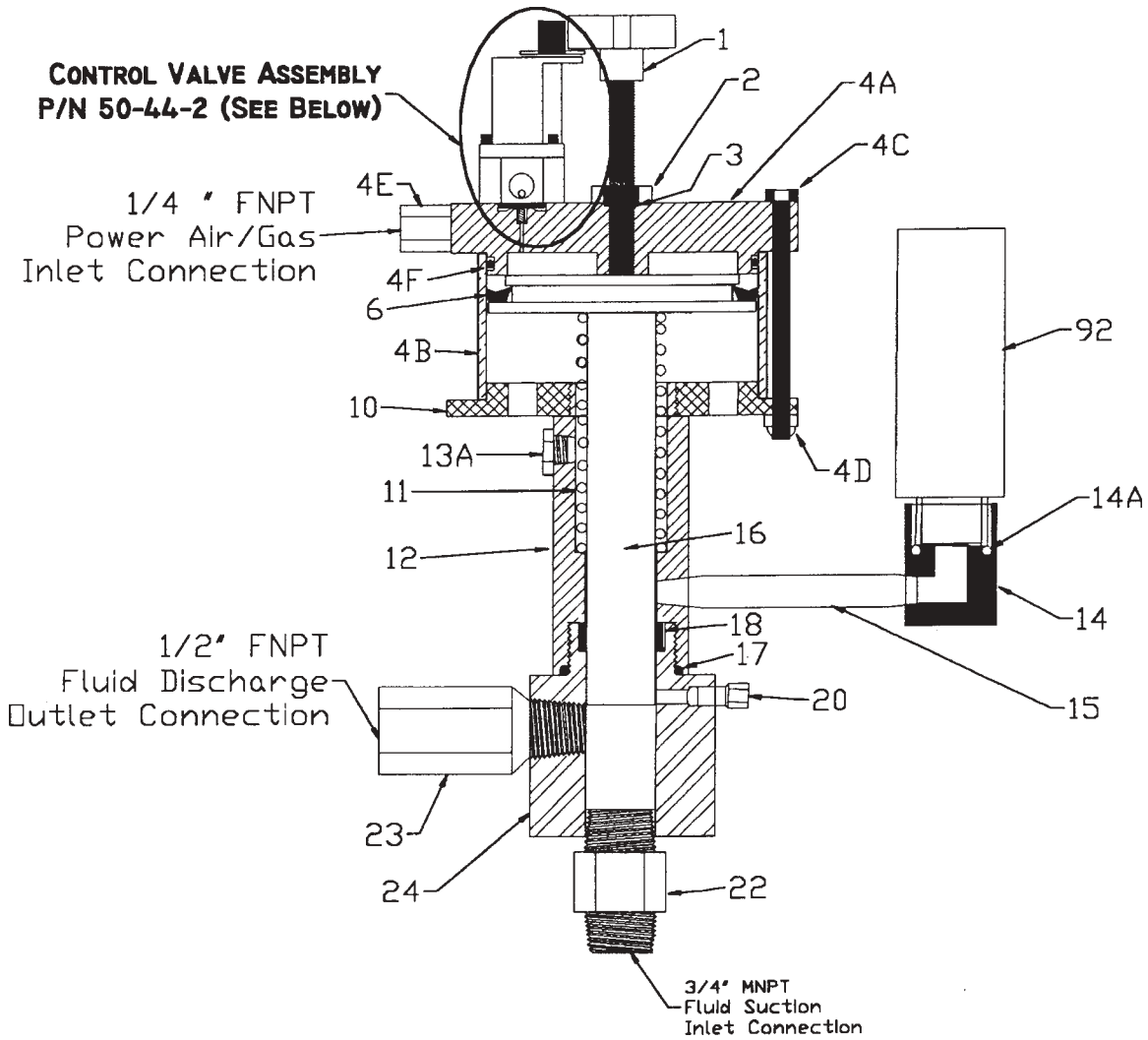

Model 44/64/84/164 Series

SIDEWINDER PUMP MODEL NUMBER CHART

Fill in boxes below to determine Sidewinder Pump Size and Material Requirements

		C					
Plunger Size		Piston Size		Plunger Material		Check Valve & Body Material	
04	0.250"	0	1.25"	0	17-4 SS (Standard)	0	Teflon Graphite Uniseal
06	0.375"	2	2.25"	2	316 SS	1	Techno Uniseal (Polyimede)
08	0.500"	4	4.00"	3	440C SS	2	Viton O-ring
16	1.00"			4	Ceramic	3	Buna O-ring
				5	Hastelloy	4	Teflon Uniseal
				6	Titanium	4B	Teflon Uniseal w/Buna O-ring Insert
				7	440C Chrome Plated	4V	Teflon Uniseal w/Viton O-ring Insert
				8	316 SS w/ Electroless Nickel Plating	5	Chemraz O-ring
						6	Hitec O-ring (Aflas)
						7	Virgin Teflon O-ring
						8	Polyblend Uniseal
						9	Special

Special Options

- 2-Viton Piston U-Cup
- 4-Ceramic Check Valve Balls
- MP- Ni Cobalt Molly Return Spring

* Production Series-Designates current factory production model. For explanation of production series please visit our website

PARTS LIST for MODEL 164 'C' SIDEWINDER PUMP

Item #	Description	Model 164 'C'
1	Stroke Adjuster	1-42
2	Locknut-Stroke Adjuster	2-42
*3	Seal-Stroke Adjuster	3-42
4A	4.00" Powerhead Cap	4A-44-2
4B	Powerhead Cylinder	4B-44-2
4C	Powerhead Tie Bolt (6 required)	4C-44-2
4D	Powerhead Tie Bolt Nut (6 required)	4D-44-2
4E	Powerhead Inlet Connector Fitting	4E-44-2
*4F	Powerhead Cap O-Ring	4F-44
*6	U-Cup (Viton U-Cup available see note 6 ^a)	6-44
10	Mounting Flange	10-164-B
*11	Return Spring (Spring options see note 11 ^a)	11-164
12	Mounting Tube	12-164
13A	Vent	13A-42
14	Lube Body	14-42
14A	Lube Body O-Ring	14A-42
15	Lube Tube	15-43
*16	Piston-Plunger Assembly <i>MATERIAL</i> 316 Stainless Steel 440 'C' Stainless Steel Stainless Steel Chrome Plated Stainless Steel with Nickel Plating Customer Specified (Consult Factory)	16-164-2 16-164-3 16-164-7 16-164-8 16-164-9
*17	Mounting Tube O-Ring	17-164
*18	Plunger Seal <i>MATERIAL</i> Teflon Graphite Uniseal Techno Uniseal (Polyimede) Viton O-Ring Buna-N O-ring Virgin Teflon Uniseal Virgin Teflon Uniseal with Viton O-Ring Insert Virgin Teflon Uniseal with Buna-N O-Ring Insert Chemraz O-Ring Hitec O-Ring Virgin Teflon O-Ring Polyblend Uniseal Customer Specified Special (Consult Factory)	18-164 18-164-1 18-164-2 18-164-3 18-164-4 N/A N/A 18-164-5 18-164-6 N/A 18-164-8 18-164-9
Note: O-Ring seals on model 164 require (1) each O-ring and (2) each narrow back up ring part number 18D-164.		
20	Bleeder Valve (316 SS)	20-42-2
*22	Suction Check Valve (316 SS)	22-164-2
*23	Discharge Check Valve (316 SS)	23-164-2
24	Fluid Pump Chamber (316 SS)	24-164-2
31	Time Knob	31-42
33	Timer Stem	33-42C
**35	Timer Stem O-Ring	35-42
51	Control Valve Cover with Timer	51T-42C-2
**52	Control Valve Diaphragm	52-42
53	Control Valve Body	53-44-2
**54	Control Valve Actuator	54-42
**55	Control Valve Poppet	55-42
**56	Control Valve Body Seal	56-42
**57	Control Valve Spring	57-42
**58	Control Valve Mounting Screw (2 required)	58-42
**75	Control Valve Mounting Screw Locknut (2 required)	75-42
*91	Piston Grease (not shown)	91-42
*92	Plunger Lube (4 Oz.) (not shown)	92-122

* Parts included in a pump end repair kit. Also included is 91-42 Silicon Piston Grease. This Kit is designated by a "K" preceding the pump model number. The B & C series in the Model 164 use the same Pump End Repair Kit.

** Parts included in timer valve repair kit. The kit part number is KVC-40F. The series "C" Control Timer Valve does not require part #37-42 O-Ring Seal in the the KVC-40 Kit.

6^a Piston U-Cup in Viton — part # 6-44-4.

11^a Return Spring in Nii Cobalt Moly - Part # 11-164-MP

Trouble Shooting The Sidewinder Chemical Pump

Problem	Possible Cause	Action
Control Valve Not Cycling	<ul style="list-style-type: none"> No supply pressure Pump speed control closed Leak in control or valve Supply gas blowing through to exhaust due to speed control too wide, trash under valve Seat or restriction in air/gas supply line. 	<ul style="list-style-type: none"> Check gauge on supply line near pump to verify adequate supply pressure . . . 10 to 150 psi. Rotate dial CCW three turns from full in position and then set desired rate. Rotate CW to slow pump rate. Check for leak, pinched or missing seals, broken diaphragm or loose mounting screws. Rotate control dial CW to decrease setting. Block exhaust momentarily and then release. DO NOT USE BARE FINGERS. If this does not work, replace Timer Seat O-Ring #37-42 or increase supply line size and move pump closer to air/gas supply source.
Piston Not Stroking	<ul style="list-style-type: none"> Return spring broken Piston stuck due to lack of Piston or Plunger Lube Supply pressure too low to buck process line pressure Stroke Length Adjuster screwed too far 	<ul style="list-style-type: none"> Replace Spring Clean and lubricat power head and piston with Piston Lube #91-42. Clean Plunger Lube Chamber and fill Plunger Lube #92-122. Change piston and plunger seals if needed. Divide process line pressure by amplification ratio (see Performance Chart). Supply pressure must exceed the result. (Standard Sidewinder Control operates from 10 to 150 psi.) Back out on stroke adjuster to desired setting.
No Fluid Discharge With Control Cycling And Piston Stroking	<ul style="list-style-type: none"> Air or vapor in pump chamber Fluid flow to pump blocked by plugged line, closed valve, extremely high viscosity or lack of fluid supply Suction or discharge check valve leaking Discharge line plugged 	<ul style="list-style-type: none"> Open bleeder valve, fill chamber with fluid only, then close bleeder valve. Provide free flow of fluid to pump suction. Use drum gauge with handle in test position to determine which valve is leaking. Clean or replace faulty valve. Clear or replace line.
Premature Seal Failure	<ul style="list-style-type: none"> Chemical incompatibility between seal and material being pumped Scored or damaged plunger Abrasive material in chemical No lubricant or incorrect lube 	<ul style="list-style-type: none"> Check a Compatibility Chart or consult chemical manufacturer, and install seal made from compatible material. Replace plunger. Install suction filter. Use Sidewinder Lube #91-42 on piston and #92-122 on plunger. Periodically check lube level.

Pump Selection Guide and Performance Chart

Model Number	Plunger Size	Piston Size	Amplification Ratio	Supply Pressure PSI(a)	Maximum Discharge Pressure	Maximum Full Strokes Per Minute	Output Volume Qts. Per Day
40	1/4"	1.25"	25:1	15 to 150	0 to 3,750	60	0 to 90
42	1/4"	2.25"	80:1	10 to 150	0 to 10,000	55	0 to 70
44	1/4"	4.00"	240:1	10 to 150	0 to 10,000	35	0 to 30
60	3/8"	1.25"	11:1	15 to 150	0 to 1,600	60	0 to 200
62	3/8"	2.25"	36:1	10 to 150	0 to 5,400	55	0 to 155
64	3/8"	4.00"	110:1	10 to 150	0 to 10,000	30	0 to 67
80	1/2"	1.25"	6.25:1	15 to 150	0 to 935	60	0 to 360
82	1/2"	2.25"	20:1	10 to 150	0 to 3,000	55	0 to 275
84	1/2"	4.00"	60:1	10 to 150	0 to 9,000	30	0 to 120
164	1"	4.00"	16:1	10 to 150	0 to 2,400	40	0 to 680